

# Homoclinic-doubling cascades

Ale Jan Homburg  
Korteweg-de Vries Institute for Mathematics  
University of Amsterdam  
Plantage Muidergracht 24  
1018 TV Amsterdam  
The Netherlands

Hiroshi Kokubu\*  
Department of Mathematics  
Kyoto University  
Kyoto 606-8502  
Japan

Vincent Naudot  
Dept. WNI  
Limburgs Universitair Centrum  
Universitaire Campus  
3590 Diepenbeek  
Belgium

## Abstract

Cascades of period-doubling bifurcations have attracted much interest from researchers of dynamical systems in the past two decades as it is one of the routes to onset of chaos. In this paper we consider routes to onset of chaos involving homoclinic-doubling bifurcations.

---

\*Partially supported by Grant-in-Aid for Scientific Research (No. 08740139), Ministry of Education, Science and Culture, Japan.

We show the existence of cascades of homoclinic-doubling bifurcations, persistently in two-parameter families of vector fields on  $\mathbb{R}^3$ . The cascades are found in an unfolding of a codimension-three homoclinic bifurcation; an orbit-flip at resonant eigenvalues. We develop a continuation theory for homoclinic orbits in order to follow homoclinic orbits through infinitely many homoclinic-doubling bifurcations.

## 1 Introduction

It is known that, under certain conditions, an orbit homoclinic to a hyperbolic singularity can undergo a homoclinic-doubling bifurcation. This creates a homoclinic orbit, referred to as a doubled or 2-homoclinic orbit, that circulates twice in a tubular neighborhood of the original homoclinic orbit. It has been made plausible by H. Kokubu, M. Komuro and H. Oka [23] that a cascade of successive homoclinic-doubling bifurcations can occur. It is the goal of this paper to rigorously establish the following result:

**Main Theorem** *In the space of two-parameter families of smooth vector fields on  $\mathbb{R}^3$  there is an open set consisting of families that possess a cascade of homoclinic-doubling bifurcations.*

A precise statement will be made in Section 2, see Theorem 2.4, once the necessary notation has been introduced. The picture to have in mind for the homoclinic-doubling bifurcation is the following: in the parameter plane of a two-parameter family of vector fields that generically unfolds such a homoclinic bifurcation there is a curve of 2-homoclinic orbits that branches from the curve of primary homoclinic orbits, at the codimension-two point. The bifurcation diagram of such a homoclinic-doubling bifurcation is depicted in Figure 1. Note that such a scenario only makes sense for two-parameter families of vector fields; homoclinic-doubling does not occur in generic one-parameter families. A cascade of successive homoclinic-doubling bifurcations arises if, as a curve of doubled homoclinic orbits is followed, a further homoclinic-doubling occurs. The homoclinic orbit, existing after  $n$  homoclinic-doubling bifurcations, forms a curve which gets arbitrarily long as  $n \rightarrow \infty$ .

It is clear that we are dealing with a situation that is global both in parameter and in phase space. Our idea to handle this problem is to consider a codimension-three homoclinic bifurcation and to show that there are cascades of homoclinic-doubling bifurcations in its unfolding. Thereby we localize the problem in the parameter space and restrict the phase space to a

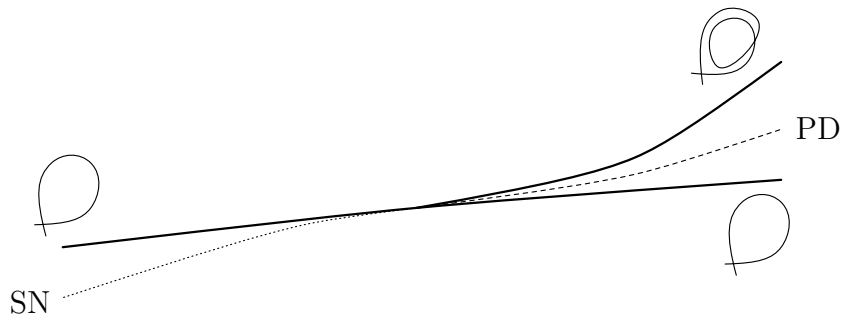

Figure 1: This figure shows the bifurcation diagram of a homoclinic-doubling bifurcation, as studied in this paper. Besides the curve of primary homoclinic orbits and the branch of doubled homoclinic orbits, there is a branch SN of periodic saddle node bifurcations and a branch PD of period-doubling bifurcations.

small tubular neighborhood of the codimension-three homoclinic orbit. The codimension-three homoclinic bifurcation we consider is an orbit-flip bifurcation at resonant eigenvalues. To be more precise, let  $X$  be a smooth vector field with a hyperbolic singularity  $p$  at which  $DX(p)$  has two real stable eigenvalues  $-\alpha, -\beta$  with  $-\alpha < -\beta < 0$  and one unstable eigenvalue, which we may assume to be equal to 1, after a time reparametrization. Assume that  $X$  has a homoclinic orbit contained in the strong stable manifold  $W^{ss}(p)$  of  $p$ . Such a homoclinic orbit is called an orbit-flip homoclinic orbit [36]. We assume the resonance condition on the eigenvalues  $\alpha = 1$  and further the eigenvalue condition  $\frac{1}{2} < \beta < 1$ . Finally, we assume that an associated number, which we call the weak eigenvalue along the homoclinic orbit, is sufficiently large. In any unfolding in a three-parameter family of vector fields, of a vector field with such an orbit-flip homoclinic orbit at resonant eigenvalues, we show the existence of cascades of homoclinic-doubling bifurcations. Actually, the homoclinic-doubling bifurcations themselves are codimension-two homoclinic bifurcations known as inclination-flips. Building on the results of this paper, the occurrence of homoclinic-doubling cascades in the unfolding of other codimension-three homoclinic bifurcations is discussed in [19]. The paper [24] discusses codimension-three homoclinic bifurcations as well, and establishes the existence of inclination-flip bifurcations of  $n$ -homoclinic orbits, for any  $n$ , in the unfolding of a particular codimension-three homoclinic bifurcation.

There exists a striking similarity of homoclinic-doubling cascades with period-doubling cascades. Indeed, in our constructed example, we can find period-doubling cascades arbitrarily near a homoclinic-doubling cascade. The existence proofs show more similarities. Period-doubling cascades for diffeomorphisms unfolding a Smale horseshoe are shown to exist using continuation results for periodic orbits [45]. Analogous results then hold for vector fields obtained from diffeomorphisms by a suspension construction. We proceed by similar techniques; in a properly defined geometric situation we apply a continuation result for homoclinic orbits. Since an appropriate continuation theory for homoclinic orbits was not available, we had to develop such a theory. The resulting theory is inspired by a continuation theory for periodic orbits by K.T. Alligood, J. Mallet-Paret and J.A. Yorke [3], [2] and a continuation theory for homoclinic orbits that applies to generic families and was developed by B. Fiedler [11].

In addition, by considering the unfolding of a codimension-three homoclinic orbit and using singularly rescaled coordinates, we obtain a Poincaré return map that is close to an interval map. This interval map is unimodal, but not smooth since it has infinite slope at one point. The reduction to (essentially) one dimensional dynamics brings a study of universal scaling properties into scope. For smooth unimodal maps, universal scaling properties of a period-doubling cascade were discovered independently by M. Feigenbaum [10] and by P. Coullet and C. Tresser [7]. They found that the period-doubling bifurcations in the cascade scale asymptotically according to a geometric law, with a convergence rate independent of the family. This universal scaling is explained by renormalization theory. As just mentioned, in our constructions we obtain a Poincaré return map that is close to an interval map. Renormalization theory and its interpretation for universal scalings in the bifurcation diagrams have been studied for a class of such interval maps in [20].

In [23], numerical evidence for the existence of a homoclinic-doubling cascade in a family of piecewise affine vector fields is provided. Our result showing that homoclinic-doubling cascades occur in the unfolding of a specific codimension-three homoclinic orbit, enables the construction of an example of a family of polynomial vector fields with a homoclinic-doubling cascade. Indeed, in [37] a recipe is given to construct polynomial vector fields with specific homoclinic orbits. Following his construction one can write down a family of vector fields unfolding a codimension-three orbit-flip homoclinic orbit at resonant eigenvalues. A numerical investigation of such

vector fields is contained in [30] by B.E. Oldeman, B. Krauskopf and A.R. Champneys, where they numerically detect a cascade of homoclinic-doubling bifurcations and study scalings in the bifurcation diagram. See also [31]. Furthermore, there is some evidence that in the Shimizu-Morioka model for studying the dynamics of Lorenz-like systems at high Rayleigh numbers, homoclinic-doubling cascades can occur, see [39].

This paper is organized as follows. In Section 2 we give a definition of the degenerate homoclinic orbit called the orbit-flip at resonant eigenvalues. This is the core object of our study, and its unfolding exhibits the homoclinic-doubling cascades. We do not intend to study the complete bifurcation diagram of this codimension-three homoclinic orbit, but rather restrict our study to a region in parameter space where one expects the cascade. For these parameters, we study a Poincaré return map. We give an asymptotic expression of a rescaled form of this Poincaré return map. The crucial observation is that the rescaled Poincaré return map can be viewed as a singular perturbation of an interval map. This rescaled Poincaré return map plays a central role in the analysis that follows.

In Section 3 we consider the family of one dimensional maps that result from the singular rescaling. We indicate the relation between its dynamics and bifurcations with that of the original family of vector fields. In Section 4 we extend the study in Section 3 to that of the two dimensional rescaled return map and prove some facts needed later. In particular we show the existence of an invariant strong stable foliation for the rescaled return map, on a subset of the parameter space. This allows for a rigorous reduction to one dimensional dynamics, for these parameter values.

Section 5 is devoted to the construction of a continuation theory for homoclinic orbits. This is inspired by a similar theory for the continuation of periodic orbits, developed in a series of papers by K.T. Alligood, J.A. Yorke and J. Mallet-Paret [25], [3], [2]. An obvious difference between continuing periodic and homoclinic orbits is that periodic orbits are continued in one-parameter families of vector fields, whereas homoclinic orbits are continued in two-parameter families of vector fields.

In Section 6 we gather all information to prove the main theorem. Applying the continuation theory to our situation it will follow that, when continuing a particular homoclinic orbit, one encounters homoclinic orbits that form curves of arbitrarily large length. Information derived from the fact that we are unfolding a particular codimension-three homoclinic orbit allows us to conclude that this can only happen through a cascade of homoclinic-doubling

bifurcations.

In Appendix A we complete the proof that the bifurcation set of generically unfolded inclination-flips, with eigenvalue conditions with which they occur in the homoclinic-doubling cascade, is as indicated in Figure 1. This was previously unknown; the bifurcations were known to be complete as far as bifurcations of  $n$ -periodic and  $n$ -homoclinic orbits for  $n = 1, 2$  are concerned.

In Appendix B we construct a normal form for vector fields near the singularity and prove validity of certain exponential expansions for a local transition map. The results of this appendix are used to study the Poincaré return map in Section 2.

**Acknowledgements** The authors acknowledge fruitful conversations with Patrick Bonckaert, Bernold Fiedler and other colleagues at the Free University in Berlin, Sergey Gonchenko, Bernd Krauskopf, Björn Sandstede, Misha Shashkov, Andrey Shil'nikov and Leonid Shil'nikov. AJH acknowledges the kind hospitality of l'Université de Bourgogne in Dijon for a visit and of Kyoto University for a two months stay.

## 2 Orbit-flip at resonant eigenvalues

In this section, we introduce a homoclinic orbit of codimension-three called orbit-flip at resonant eigenvalues. Homoclinic-doubling cascades will be found in its unfolding. After giving some definitions, we provide a precise statement of our main result in Theorem 2.4 below. This section is further devoted to the study of a Poincaré return map on a cross-section transverse to the codimension-three orbit-flip homoclinic orbit.

Let  $X$  be a smooth vector field on  $\mathbb{R}^3$  with a hyperbolic singularity  $q$ . We assume that  $DX(q)$  has two distinct real stable eigenvalues and one unstable eigenvalue. By a time reparametrization, we may assume the unstable eigenvalue to be equal to 1. Write  $-\alpha, -\beta$  with  $\alpha > \beta > 0$  for the two stable eigenvalues. Because the two stable eigenvalues are distinct, the vector field  $X$  has, contained in the stable manifold  $W^{ss,s}(q)$  of  $q$ , a one dimensional strong stable manifold  $W^{ss}(q)$ . Its tangent space at  $q$  is the eigenspace associated to  $-\alpha$ . There further exists a two dimensional center unstable manifold  $W^{s,u}(q)$  with tangent space at  $q$  spanned by the eigenspaces associated to the eigenvalues  $-\beta$  and 1. This last invariant manifold is not unique and in general it is only  $C^1$  [16]. The tangent bundle of (any)  $W^{s,u}(q)$  along the unstable manifold, however, is a uniquely determined smooth bundle, see

e.g. [18] for a proof of this fact. All these invariant manifolds persist under perturbation of the vector field. We write  $W_X^{ss,s}(q), W_X^{s,u}(q)$ , etc., if we wish to stress the dependence of these manifolds on the vector field  $X$ .

**Definition 2.1** Suppose  $\Gamma$  is a homoclinic orbit of  $X$ , that is, a nontrivial intersection of  $W^{ss,s}(q)$  with  $W^u(q)$ .  $\Gamma$  is called an *inclination-flip* homoclinic orbit, if  $W^{ss,s}(q)$  is tangent to one (and hence any) center unstable manifold  $W^{s,u}(q)$  along  $\Gamma$ .  $\Gamma$  is called an *orbit-flip* homoclinic orbit, if  $\Gamma \subset W^{ss}(q)$ .

Inclination-flips and orbit-flips are examples of homoclinic bifurcations of (at least) codimension-two. We will not make precise the notion of codimension. What is heuristically meant with a bifurcation being of codimension- $n$ , is that it is given by a collection of conditions, naturally occurring in its study, that make up a manifold of codimension- $n$  in the space of vector fields. Compare also Subsection 5.1.

**Definition 2.2** Let  $\{X_\gamma\}, \gamma \in \mathbb{R}^d$ , be a smooth unfolding of  $X = X_0$  possessing a homoclinic orbit  $\Gamma$  at  $\gamma = 0$ . Let  $S$  be a cross-section intersecting  $\Gamma$  transversally at a single point. We say that  $\Gamma$  creates a *homoclinic orbit of order  $N$*  or an  *$N$ -homoclinic orbit* in the family  $\{X_\gamma\}$ , if for any neighborhood  $\mathcal{V} \subset \mathbb{R}^d$  of 0 and for any tubular neighborhood  $\mathcal{T}$  of the closure of  $\Gamma$ , there exists  $\gamma \in \mathcal{V}$  such that  $X_\gamma$  possesses a homoclinic orbit in  $\mathcal{T}$  intersecting  $S \cap \mathcal{T}$  in  $N$  points.

The next proposition serves to introduce the notion of weak eigenvalue along an orbit-flip homoclinic orbit. This is defined only if there is the resonance  $\alpha = 1$  among the eigenvalues of  $DX(q)$ . A related notion, that of weak direction, was considered in [28].

**Proposition 2.3** *Suppose that  $\Gamma$  is an orbit-flip homoclinic orbit of a vector field  $X$  as above. Suppose that  $\alpha = 1$ . Let  $S$  be a cross-section transverse to  $\Gamma$  and let  $\Phi : S \rightarrow S$  be the Poincaré return map on  $S$ . Let  $\mathcal{C} = \{\mathcal{C}(t) \mid t \in (-1, 1)\}$  be a  $C^1$  curve in  $S$ , transverse to  $W^{ss,s}(q)$  at  $\mathcal{C}(0) = W^{ss}(q) \cap S$ , with  $\mathcal{C}(t)$  in the domain of  $\Phi$  for  $t > 0$ . Then the limit*

$$\lim_{t \downarrow 0} D\Phi(\mathcal{C}(t))$$

*exists as a  $2 \times 2$  matrix which has two eigenvalues  $\mathcal{A}$  and 0. The eigenvalue  $\mathcal{A}$  depends neither on the choice of the cross-section  $S$  nor on the curve  $\mathcal{C}$ .*

PROOF. By a theorem of G.R. Belitskii [4], there is a  $C^1$  local coordinate change that makes the vector field  $X$ , near the singularity  $q$ , linear. In such coordinates one has an explicit expression of a local transition map. The proof is now given by a straightforward computation, which we leave to the reader.  $\square$

It should be noted that the Poincaré return map  $\Phi$  is defined only on a subset of the section  $S$ . Here and throughout the paper we find it convenient to speak of the Poincaré return map on a cross section, even though its domain is actually a subset of the cross section. We call the eigenvalue  $\mathcal{A}$  the *weak eigenvalue* along  $\Gamma$ .

Consider a smooth three-parameter family of vector fields  $\{X_\gamma\}$ ,  $\gamma \in \mathbb{R}^3$ , on  $\mathbb{R}^3$  satisfying the following conditions:

**(BH: Basic hypothesis)** The vector field  $X_\gamma$  has a hyperbolic singularity  $q_\gamma$  at which the linearization  $DX_\gamma(q_\gamma)$  possesses two negative eigenvalues  $-\alpha(\gamma) < -\beta(\gamma)$  and one positive eigenvalue 1.

**(OF: Orbit-flip)** The vector field  $X_0$  possesses, at the parameter  $\gamma = 0$ , an orbit-flip homoclinic orbit  $\Gamma$ . The stable manifold  $W_{X_0}^{ss,s}(q_0)$  intersects any center unstable manifold  $W_{X_0}^{s,u}(q_0)$  transversally along  $\Gamma$ .

**(SR: Strong resonance)** The eigenvalues of the linearization  $DX_0(q_0)$  satisfy

$$\alpha(0) = 1 \text{ and } \frac{1}{2} < \beta(0) < 1.$$

**(WE: Weak eigenvalue)** The weak eigenvalue  $\mathcal{A}$  along  $\Gamma$  satisfies

$$\mathcal{A} > \frac{1}{1 - \beta(0)} \left( \frac{1}{\beta(0)} \right)^{\frac{\beta(0)}{1 - \beta(0)}}.$$

**(GU: Generic unfolding)**  $\bigcup_{\gamma} (W_{X_\gamma}^{ss}(q_\gamma), \alpha(\gamma), \gamma)$  and  $\bigcup_{\gamma} (W_{X_\gamma}^u(q_\gamma), \alpha(\gamma), \gamma)$  intersect transversally along  $\Gamma \times \{1\} \times \{0\}$  in  $\mathbb{R}^3 \times \mathbb{R} \times \mathbb{R}^3$ .

Let  $S$  be a cross-section transverse to  $\Gamma$ . Take coordinates  $(x, y)$  on  $S$  so that  $W_{X_\gamma}^{ss}(q_\gamma)$  intersects  $S$  in  $(0, 0)$  and  $W_{X_\gamma}^{ss,s}(q_\gamma)$  intersects  $S$  in  $\{x = 0\}$ . We may further assume that the domain of the Poincaré return map on  $S$



is contained in  $\{x > 0\}$ . Write  $(\varepsilon(\gamma), \omega(\gamma))$  for the coordinates of the first intersection of  $W_{X_\gamma}^u(q_\gamma)$  with  $S$ . Define  $\mu(\gamma) = \alpha(\gamma) - 1$ . By the generic unfolding condition (GU), one may, by reparametrizing the parameter space, assume that  $\gamma = (\varepsilon, \omega, \mu)$ .

The next theorem gives the class of vector fields for which we prove the existence of homoclinic-doubling cascades.

**Theorem 2.4** *Let  $\{X_\gamma\}$ ,  $\gamma = (\varepsilon, \omega, \mu) \in \mathbb{R}^3$ , be a smooth three-parameter family of vector fields as above. For each  $\varepsilon$  sufficiently small and positive, the two-parameter family  $\{Y_{\omega, \mu}\}$  given by  $Y_{\omega, \mu} = X_{\varepsilon, \omega, \mu}$ , possesses a connected set of homoclinic bifurcation values in the  $(\omega, \mu)$ -parameter plane, containing a cascade  $(\omega_n, \mu_n)$  of homoclinic-doubling bifurcations in which a  $2^n$ -homoclinic orbit is created. Moreover, each such homoclinic-doubling bifurcation is an inclination-flip and each  $\mu_n$  as well as  $\lim_{n \rightarrow \infty} \mu_n$  is positive.*

The main result, as formulated in the introduction, is a consequence of this theorem. The geometry of the flow of the vector fields occurring in the above theorem is discussed in Section 2.1 below (and illustrated in Figure 2), by considering first return maps on a cross section. Theorem 2.4 holds for any family satisfying the conditions (BH) to (GU) and so holds for an open set of three-parameter families of vector fields.

Note that the eigenvalues of  $DX_\gamma(q_\gamma)$  at  $\gamma = (\varepsilon, \omega_n, \mu_n)$ , satisfy  $\alpha(\gamma) > 1$  and  $\frac{1}{2} < \beta(\gamma) < 1$ . We refer to the appendix for a precise statement on the unfolding of inclination-flips with these eigenvalue conditions. These eigenvalue conditions are relevant since for other conditions an unfolding of an inclination-flip has a different bifurcation diagram [21], [17], [28]. Observe also that higher order homoclinic orbits can only occur for  $\varepsilon > 0$ , when  $W^u(q_\gamma)$  intersects  $S$  in the domain of the Poincaré return map on  $S$ .

## 2.1 Return maps

Let  $\{X_\gamma\}$  be a smooth three-parameter family of vector fields, satisfying the conditions (BH) to (GU) above. Without loss of generality we may assume that the singularity  $q_\gamma$  is the origin  $O$ . Take coordinates  $(x_{ss}, x_s, x_u) \in \mathbb{R}^3$  so that  $X_\gamma$  is given by a set of ordinary differential equations;

$$\begin{aligned} \dot{x}_{ss} &= -\alpha(\gamma)x_{ss} + H_{ss}(x_{ss}, x_s, x_u; \gamma), \\ \dot{x}_s &= -\beta(\gamma)x_s + H_s(x_{ss}, x_s, x_u; \gamma), \\ \dot{x}_u &= x_u + H_u(x_{ss}, x_s, x_u; \gamma), \end{aligned} \tag{2.1}$$

where  $D^i H_{ss}(O; \gamma), D^i H_s(O; \gamma), D^i H_u(O; \gamma) = 0$  for  $i = 0, 1$ .

For suitably small  $\delta$  let

$$S = \{x_{ss} = \delta, |x_s|, |x_u| \leq \delta\},$$

so that  $S$  is a cross-section transverse to  $\Gamma$ . The following proposition, giving information on the Poincaré return map on  $S$ , is the main result of Section 2. Its proof will occupy the rest of the section.

**Proposition 2.5** *Let  $\{X_\gamma\}$  be as above and let  $\Phi_\gamma : S \rightarrow S$  be the Poincaré return map associated to  $X_\gamma$ . Let  $\mathcal{A}$  be the weak eigenvalue along the homoclinic orbit  $\Gamma$ . For all compact intervals  $\mathbb{I}, \mathbb{J} \subset (0, \infty)$  and all positive real numbers  $A_x, A_y$ , there exist  $\varepsilon_0 > 0$ , a diffeomorphism*

$$\sigma^p : (0, \varepsilon_0] \times \mathbb{I} \times \mathbb{J} \rightarrow \mathbb{R}^3,$$

and a smooth family of diffeomorphisms

$$\sigma_{\varepsilon,p,r}^v : (0, A_x] \times [-A_y, A_y] \rightarrow S$$

depending on parameters  $(\varepsilon, p, r) \in (0, \varepsilon_0] \times \mathbb{I} \times \mathbb{J}$ , so that the map  $\Psi_{\varepsilon,p,r} : (0, A_x] \times [-A_y, A_y] \rightarrow \mathbb{R}^2$ , given by

$$\Psi_{\varepsilon,p,r} = (\sigma_{\varepsilon,p,r}^v)^{-1} \circ \Phi_{\sigma^p(\varepsilon,p,r)} \circ \sigma_{\varepsilon,p,r}^v,$$

has the following expression:

$$\Psi_{\varepsilon,p,r}(x, y) = \begin{pmatrix} f(x; \varepsilon, p, r) + h_1(x, y; \varepsilon, p, r) \\ h_2(x, y; \varepsilon, p, r) \end{pmatrix},$$

where

$$f(x; \varepsilon, p, r) = p + \frac{r}{1 - \beta} (\beta x^\alpha - x^\beta)$$

and  $h_i$ ,  $i = 1, 2$ , satisfies

$$|h_i(x, y; \varepsilon, p, r)|, \left| x \frac{\partial h_i}{\partial x}(x, y; \varepsilon, p, r) \right|, \left| \frac{\partial h_i}{\partial y}(x, y; \varepsilon, p, r) \right| \leq C_\varepsilon |x|^\beta,$$

for some  $C_\varepsilon > 0$  with  $C_\varepsilon \rightarrow 0$  as  $\varepsilon \rightarrow 0$ .

**Remark 2.6** For  $\varepsilon = 0$ ,  $\Psi_{0,p,r}(x, y) = (f_{p,r}(x), 0)$  with

$$f_{p,r}(x) = p - \frac{1}{1 - \beta(0)} r x^{\beta(0)} + \frac{\beta(0)}{1 - \beta(0)} r x.$$

**Remark 2.7** It will follow from the expression for  $\sigma^p$  that, at  $\varepsilon = 0$ ,  $\mu$  is positive for  $r < \mathcal{A}^{\frac{1-\beta(0)}{\beta(0)}}$ . By condition (WE) on the weak eigenvalue along  $\Gamma$ , this is the case if  $r < \frac{1}{\beta(0)}^{1/(1-\beta(0))}$ . This particular value will play a role later.

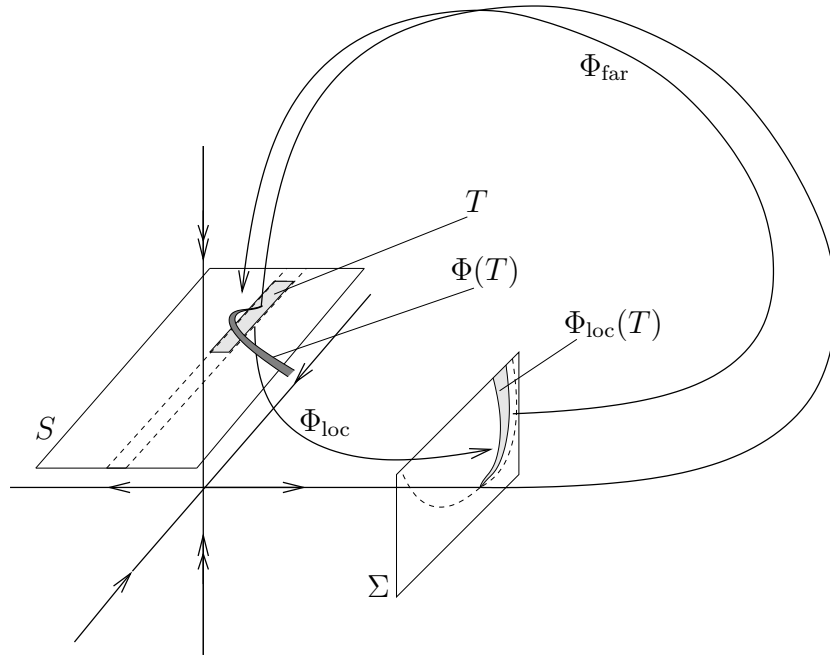

Figure 2: This figure illustrates the presence of close to unimodal maps in first return maps for a vector field  $X_\gamma$ ,  $\gamma = (\varepsilon, \omega, \mu)$ , as stated in Proposition 2.5. The strip  $T = \sigma_{\varepsilon,p,r}^v(\Delta)$  is mapped to a cusp shaped region by the first return map  $\Phi = \Phi_{\text{far}} \circ \Phi_{\text{loc}}$  (the local and global transition maps  $\Phi_{\text{loc}} : S \rightarrow \Sigma$  and  $\Phi_{\text{far}} : \Sigma \rightarrow S$  are studied in Section 2.2). The correct scale is given by the map  $\sigma_{\varepsilon,p,r}^v$  and given explicitly in Section 2.3.

It should be noted that the rescaling in the above proposition, applies only in a subregion of the combined phase-parameter space  $S \times \mathbb{R}^3$ . Indeed,

it applies only to values from  $S \times \mathbb{R}^3$  that lie in the image of  $(\sigma_{\varepsilon,p,r}^v, \sigma^p)$ . The importance of the rescaling lies in the fact that the rescaled Poincaré return map is close to a one-dimensional map. Singular rescalings have been applied in the study of homoclinic bifurcations in [28], [29], [24].

## 2.2 Transition maps

The remainder of Section 2 is an exposition of the proof of Proposition 2.5. The proof is divided into two steps. The first step, in this subsection, involves computing an asymptotic expression for a local transition map. The proof of the main result of this subsection, Proposition 2.9, is postponed to Appendix B. The second step, in the next subsection, is then the introduction of rescaled coordinates and the computation of the rescaled Poincaré return map, in these rescaled coordinates.

Starting from the differential equations (2.1) we will perform a number of local coordinate changes that bring the differential equations, near the origin, in a better manageable form. By a smooth coordinate change we may straighten the local strong stable, the local stable and the local unstable manifold of  $q$ ;

$$W_{loc}^{ss}(q) \subset \{x_s, x_u = 0\}, \quad (2.2)$$

$$W_{loc}^{ss,s}(q) \subset \{x_u = 0\}, \quad (2.3)$$

$$W_{loc}^u \subset \{x_{ss}, x_s = 0\}, \quad (2.4)$$

By (2.3), the function  $H_u$  in (2.1) is of  $\mathcal{O}(x_u)$ . We can therefore multiply the vector field  $X_\gamma$  near the origin by the smooth positive function  $(x_u + H_u(x_{ss}, x_s, x_u; \gamma))/x_u$ . Note that this is equivalent to performing a state dependent rescaling of time. Denoting the obtained vector field still by  $X_\gamma$ ,  $X_\gamma$  is given by a set of ordinary differential equations

$$\begin{aligned} \dot{x}_{ss} &= -\alpha(\gamma)x_{ss} + F_{ss}(x_{ss}, x_s, x_u; \gamma), \\ \dot{x}_s &= -\beta(\gamma)x_s + F_s(x_{ss}, x_s, x_u; \gamma), \\ \dot{x}_u &= x_u. \end{aligned} \quad (2.5)$$

The next lemma is proved in Appendix B.

**Lemma 2.8** *There are smooth local coordinates in which*

$$\begin{aligned} F_{ss}(x_{ss}, x_s, x_u; \gamma) &= \mathcal{O}(\|(x_{ss}, x_s)\|^2), \\ F_s(x_{ss}, x_s, x_u; \gamma) &= \mathcal{O}(\|(x_{ss}, x_s)\|^2). \end{aligned}$$

□

For some small positive  $\delta$ , define cross-sections

$$S = \{x_{ss} = \delta, |x_s|, |x_u| = \delta\}, \quad (2.6)$$

$$\Sigma = \{x_u = \delta, |x_{ss}|, |x_s| = \delta\}. \quad (2.7)$$

We may assume that  $S$  and  $\Sigma$  intersect the homoclinic orbit  $\Gamma$  transversally. By a linear rescaling we may assume that  $\delta = 1$ . On  $S$  we use  $(x_s, x_u)$  as coordinates. Likewise, on  $\Sigma$  we use  $(x_{ss}, x_s)$  as coordinates. The proof of the following proposition is contained in Appendix B. Essential for the expansions is the eigenvalue condition (SR).

**Proposition 2.9** *The local transition map  $\Phi_{\text{loc}} : S \rightarrow \Sigma$ , for the vector field (2.5), has the following expression for its components  $\Phi_{\text{loc}} = (\Phi_{\text{loc}}^{ss}, \Phi_{\text{loc}}^s)$ :*

$$\begin{aligned} \Phi_{\text{loc}}^{ss}(x_s, x_u; \gamma) &= x_u^\alpha (\psi^{ss}(x_s; \gamma) + R^{ss}(x_s, x_u; \gamma)), \\ \Phi_{\text{loc}}^s(x_s, x_u; \gamma) &= x_u^\beta (x_s \psi^s(x_s; \gamma) + R^s(x_s, x_u; \gamma)). \end{aligned} \quad (2.8)$$

Here  $\psi^{ss}, \psi^s$  are smooth nonzero functions. Furthermore,  $R^{ss}$  and  $R^s$  are smooth for  $x_u > 0$ ; for each  $0 < \sigma^{ss} < 2\beta - \alpha$  and  $0 < \sigma^s < \beta$ , there exist constants  $C_{k+l} > 0$  so that

$$\begin{aligned} \left| \frac{\partial^{k+l}}{\partial x_u^k \partial (x_s, \gamma)^l} R^{ss}(x_s, x_u; \gamma) \right| &\leq C_{k+l} x_u^{\sigma^{ss}-k}, \\ \left| \frac{\partial^{k+l}}{\partial x_u^k \partial (x_s, \gamma)^l} R^s(x_s, x_u; \gamma) \right| &\leq C_{k+l} x_u^{\sigma^s-k}, \end{aligned}$$

for nonnegative integers  $k, l$ . □

The components  $(\Phi_{\text{far}}^s, \Phi_{\text{far}}^u)$  of the global transition map  $\Phi_{\text{far}} : \Sigma \rightarrow S$  can be written as

$$\Phi_{\text{far}}^s(x_{ss}, x_s; \gamma) = \omega(\gamma) + Ax_{ss} + Bx_s + Q_1(x_{ss}, x_s; \gamma), \quad (2.9)$$

$$\Phi_{\text{far}}^u(x_{ss}, x_s; \gamma) = \varepsilon(\gamma) + Cx_{ss} + Dx_s + Q_2(x_{ss}, x_s; \gamma), \quad (2.10)$$

where  $\varepsilon$  and  $\omega$  vanish for  $\gamma = 0$ , and  $Q_1$  and  $Q_2$  are quadratic and higher order terms. Also  $A, B, C, D$  depend on  $\gamma$ , we suppress this dependence from the notation. The Poincaré return map  $\Phi : S \rightarrow S$  for the vector field  $X_\gamma$  is the composition of the local and global transition maps,  $\Phi = \Phi_{\text{far}} \circ \Phi_{\text{loc}}$ .

Write  $\Phi = (\Phi^s, \Phi^u)$ . From (2.9), (2.10) and Proposition 2.9 we obtain that for some  $\sigma > 0$ ,

$$\begin{aligned} \Phi^s(x_s, x_u; \gamma) = \\ \omega(\gamma) + \tilde{A}x_u^\alpha + \tilde{B}x_sx_u^\beta + \mathcal{O}(x_u^{\alpha+\sigma} + x_sx_u^\alpha + x_s^2x_u^\beta), \end{aligned} \quad (2.11)$$

$$\begin{aligned} \Phi^u(x_s, x_u; \gamma) = \\ \varepsilon(\gamma) + \tilde{C}x_u^\alpha + \tilde{D}x_sx_u^\beta + \mathcal{O}(x_u^{\alpha+\sigma} + x_sx_u^\alpha + x_s^2x_u^\beta), \end{aligned} \quad (2.12)$$

where  $\tilde{A} = A\psi^{ss}(0; \gamma)$ ,  $\tilde{B} = B\psi^s(0; \gamma)$ ,  $\tilde{C} = C\psi^{ss}(0; \gamma)$  and  $\tilde{D} = D\psi^s(0; \gamma)$ .

### 2.3 Singular rescalings

Using the asymptotic expression of the Poincaré return map  $\Phi : S \rightarrow S$  in the normal form coordinates, obtained in the previous subsection, we complete the proof of Proposition 2.5.

PROOF OF PROPOSITION 2.5. Define

$$\mu(\gamma) = \alpha(\gamma) - 1. \quad (2.13)$$

Let  $\varepsilon(\gamma)$  and  $\omega(\gamma)$  be as in (2.9), (2.10). By the generic unfolding condition (GU), the map  $\gamma \mapsto (\varepsilon(\gamma), \omega(\gamma), \mu(\gamma))$  is a local diffeomorphism. We may and therefore do assume that for small values of  $\gamma$ ,  $\gamma = (\varepsilon, \omega, \mu)$ .

Let  $\mathcal{A}$  be the weak eigenvalue along  $\Gamma$ . A straightforward computation shows that  $\mathcal{A}$  equals the value of  $\tilde{C}$  at  $\gamma = 0$ .

The Poincaré return map  $\Phi = (\Phi^s, \Phi^u)$  on  $S$  has the expression given by (2.11), (2.12). Let  $\mathbb{I}, \mathbb{J}$  be compact intervals in  $(0, \infty)$  and let  $A_x, A_y$  be positive real numbers. We define the maps

$$\sigma^p : (0, \varepsilon_0] \times \mathbb{I} \times \mathbb{J} \rightarrow \mathbb{R}^3, \quad (\varepsilon, p, r) \mapsto (\varepsilon, \mu, \omega)$$

and

$$\sigma_{\varepsilon, p, r}^v : (0, A_x] \times [-A_y, A_y] \rightarrow S, \quad (x, y) \mapsto (x_s, x_u)$$

implicitly by the following identities.

$$r = \left(\frac{\varepsilon}{p}\right)^\mu \frac{1-\beta}{\beta} \tilde{C}, \quad (2.14)$$

$$p^{\alpha-\beta} = -\frac{\varepsilon^{\alpha-\beta}}{\omega} \frac{\tilde{C}}{\beta \tilde{D}}, \quad (2.15)$$

$$x_u = \varepsilon \frac{x}{p}, \quad (2.16)$$

$$x_s = \varepsilon^\beta y - \varepsilon^{\alpha-\beta} \frac{\tilde{C}}{p^{\alpha-\beta} \beta \tilde{D}}. \quad (2.17)$$

Note that  $\tilde{D} \neq 0$ , since  $\Gamma$  is not an inclination-flip homoclinic orbit. From (2.14) we obtain

$$\mu = \frac{\ln\left(\frac{\beta r}{\tilde{C}(1-\beta)}\right)}{\ln\left(\frac{\varepsilon}{p}\right)}. \quad (2.18)$$

This makes clear that, for  $\varepsilon_0$  sufficiently close to 0,  $\sigma^p$  and  $\sigma_{\varepsilon,p,r}^v$  are well defined.

A direct computation using (2.11), (2.12) gives the expression of  $\Psi_{\varepsilon,p,r}$ . Remark 2.6 follows since  $\mu, \omega \rightarrow 0$  as  $\varepsilon \rightarrow 0$ . Remark 2.7 follows easily from (2.18).  $\square$

### 3 Dynamics of the interval maps

In the previous section, we derived the rescaled Poincaré map  $\Psi_{\varepsilon,p,r}$ , which is a singular perturbation of the map

$$(x, y) \mapsto (f_{p,r}(x), 0), \quad (3.1)$$

with the one dimensional map  $f_{p,r}$  given by

$$f_{p,r}(x) = p - \frac{1}{1-\beta} r x^\beta + \frac{\beta}{1-\beta} r x, \quad (3.2)$$

where we have written  $\beta$  for  $\beta(0)$  (recall that  $\frac{1}{2} < \beta < 1$ ). In this section, we shall study the dynamics and the bifurcation structure of the family  $\{f_{p,r}\}$ .

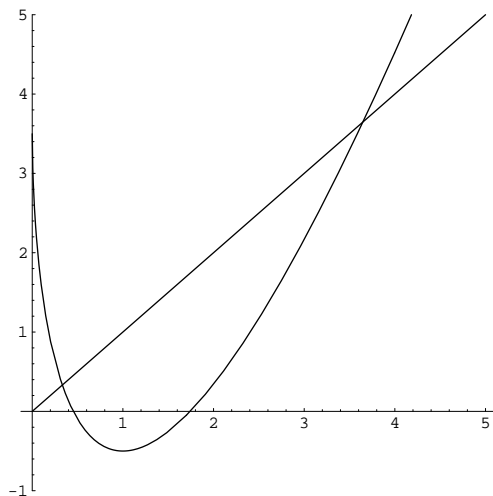

Figure 3: For each  $p, r$ ,  $f_{p,r}$  given by (3.2) is a unimodal map with its critical point at  $x = 1$ . Note that  $f(1) = p - r$  and  $f(0) = p$ . If  $p - r < 0$ ,  $p > 0$  and  $r > (1 - \beta)/\beta$ ,  $f_{p,r}$  has two fixed points.

We consider  $f_{p,r}$  defined on  $[0, \infty)$ . Observe that  $\{f_{p,r}\}$  is a family of unimodal maps, with a critical point at  $x = 1$ , which are not differentiable at  $x = 0$ . The role of the parameters  $p, r$  is indicated in Figure 3.

Homoclinic bifurcations and bifurcations of periodic orbits for the vector fields we study, naturally correspond to bifurcations of the reduced one dimensional maps  $\{f_{p,r}\}$ . For homoclinic bifurcations, the correspondence is as follows.

**Homoclinic orbit of order  $n$ :** Since the unstable manifold of the vector field is the orbit of the origin of the cross section  $\Sigma$  (see the previous section), an  $n$ -periodic orbit of  $f_{p,r}$  through 0 is interpreted as an  $n$ -homoclinic orbit of the vector field. We therefore refer to such a periodic orbit as a homoclinic orbit of  $f_{p,r}$ . The bifurcation set  $\mathbf{H}_n$  for  $n$ -homoclinic orbits of  $\{f_{p,r}\}$  is thus given by

$$f_{p,r}^n(0) = 0. \quad (3.3)$$

**Inclination-flip homoclinic orbit of order  $n$ :** An  $n$ -periodic orbit of  $f_{p,r}$  that goes through 0 and the critical point 1 in successive iterates, is



interpreted as an inclination-flip homoclinic orbit of order  $n$ . The corresponding bifurcation set  $\mathbf{IF}_n$  is given by

$$f_{p,r}^n(0) = 0 \quad \text{and} \quad \frac{\partial f_{p,r}}{\partial x}(f_{p,r}^{n-1}(0)) = 0,$$

which is equivalent to

$$f_{p,r}^n(0) = 0 \quad \text{and} \quad f_{p,r}^{n-1}(0) = 1. \quad (3.4)$$

In particular,  $\mathbf{IF}_n$  occurs only on the diagonal line  $p = r$ .

### 3.1 Homoclinic-doubling cascades for the interval maps

For parameter values on the diagonal  $p = r$  in the parameter plane, the one-parameter family  $\{\tilde{f}_p\}$ , given by

$$\tilde{f}_p(x) = f_{p,p}(x) = p \left( 1 - \frac{1}{1-\beta} x^\beta + \frac{\beta}{1-\beta} x \right),$$

satisfies  $\tilde{f}_p(1) = 0$ . That is, the critical value of  $\tilde{f}$  is 0. Since inclination-flips correspond to periodic orbits containing both 0 and 1, see (3.4),  $\mathbf{IF}_n$  is contained in the diagonal  $p = r$ . To find a cascade of parameter values  $p_n \in \mathbf{IF}_{2^n}$ , it thus suffices to consider the one-parameter family  $\{\tilde{f}_p\}$ . Such a cascade is the analogue, in the context of the one dimensional maps  $\{f_{p,r}\}$ , of the sought-for homoclinic-doubling cascade.

Observe that, at  $p = 1$ , the critical point 1 is on a 2-periodic orbit of  $\tilde{f}_1$ . At  $p = \rho = \beta^{-\frac{1}{1-\beta}}$ ,  $\tilde{f}_\rho$  is a unimodal map, mapping  $[0, \rho]$  onto itself. We want to conclude from these facts that  $\{\tilde{f}_p\}$ ,  $p \in [1, \rho]$ , is a full family, and so contains maps with any kneading sequence, compare [26]. Because  $\{\tilde{f}_p\}$  is not a family of  $C^1$  maps, this can not be concluded directly. However, applying the coordinate change  $\sigma(x) = x^{1/\beta}$ , we get a family of maps  $\{\hat{f}_p\}$ , given by  $\hat{f}_p = \sigma^{-1} \circ \tilde{f}_p \circ \sigma$ , that are continuously differentiable. This is a consequence of the facts that  $|\tilde{f}_p(x)| = \mathcal{O}(|x-1|^{2\beta})$  for  $x$  near the critical point 1, and  $2\beta > 1$ . It follows that  $\{\tilde{f}_p\}$  with  $p \in [1, \rho]$ , is a full family. In particular the family  $\{\tilde{f}_p\}$  contains a cascade of parameter values  $p_n$  in  $\mathbf{IF}_{2^n}$ . See [23] for an alternative argument.

The same argument also works for parameter values satisfying  $p > r$ , where  $f_{p,r}(1) = p - r$  is positive. In fact, under the condition that  $p > r$ ,

$f_{p,r}(p-r) = 1$  implies that  $f_{p,r}$  has a super-stable 2-periodic point, whereas  $f_{p,r}^2(p-r) = f_{p,r}(p-r)$  implies that  $f_{p,r}$  is a unimodal map from the interval  $[p-r, f(p-r)]$  onto itself. Therefore along any path in the region  $\{(p, r) \in \mathbb{R}^2; p > r\}$  in the parameter plane connecting these two curves, the family  $\{f_{p,r}\}$  forms a full family. One can conclude that  $\{f_{p,r}\}$  along such a curve admits a cascade of period-doubling bifurcations.

## 3.2 Combinatorics of homoclinic orbits

It is clear that homoclinic bifurcations for  $\{f_{p,r}\}$  can only occur if  $0 \leq p \leq r$ , when the critical value of  $f_{p,r}$  is negative. The following renormalization argument shows that, along lines in the parameter plane where  $p-r$  has a constant negative value, there are cascades of homoclinic bifurcations. Restrict  $f_{p,r}$  to  $M = \{x, 0 \leq f_{p,r}(x) \leq p\}$ , which is a union of two intervals. One can define a renormalization of  $\{f_{p,r}\}$  as follows. Renormalization is defined if  $0 \leq f_{p,r}^2(0) \leq Q$ , where  $Q$  is the orientation reversing fixed point of  $f_{p,r}$ . The renormalized map is the first return map on the interval  $[0, f_{p,r}^2(0)]$ .

Suppose the parameters  $p, r$  are functions of one parameter  $\mu \in [\mu^-, \mu^+]$ . Thus we obtain a one-parameter family  $\{f_\mu\}$ ,  $\mu \in [\mu^-, \mu^+]$ . Suppose  $p(\mu) < r(\mu)$  for all  $\mu$  and  $f_{\mu^-}^2(0) \leq 0$ ,  $f_{\mu^+}^2(0) \geq f_{\mu^+}(0)$ . For such a family one can find a subinterval  $[\mu_1^-, \mu_1^+]$  of  $[\mu^-, \mu^+]$  so that  $f_\mu$  is renormalizable for  $\mu \in [\mu_1^-, \mu_1^+]$ . Writing  $\mathcal{R}f_\mu$  for the renormalized map, we have  $(\mathcal{R}f_{\mu_1^-})^2(0) = 0$  and  $(\mathcal{R}f_{\mu_1^+})^2(0) = \mathcal{R}f_{\mu_1^+}(0)$ . So the renormalized family satisfies the same properties as the original family, allowing the conclusion that  $f_\mu$  possesses infinitely renormalizable maps. This implies the existence of a cascade of parameter values  $\mu_n \in \mathbf{H}_{2^n}$  for  $\{f_\mu\}$ .

More precise knowledge is obtained from symbolic dynamics, which we will shortly describe. For each point  $x \in M$ , an itinerary  $\mathcal{I}(x)$  is defined as a finite or infinite sequence  $\mathcal{I}_j(x)$ ,  $j \geq 0$ , of symbols  $L$  and  $R$ , according to the following rule.

$$\mathcal{I}_j(x) = \begin{cases} L, & \text{if } f_\mu^j(x) < 1, \\ R, & \text{if } f_\mu^j(x) > 1. \end{cases}$$

If  $f_\mu^j(x)$  is outside of  $M$ , that is, if  $f_\mu^j(x) < 0$  or if  $f_\mu^j(x) > \rho$ , then  $\mathcal{I}_k(x)$  is not defined for  $k \geq j+1$ .

One defines an ordering on itineraries as follows. Let  $\mathcal{I}, \mathcal{J}$  be two itineraries. Then  $\mathcal{I} < \mathcal{J}$  if for the first integer  $j$  with  $\mathcal{I}_j \neq \mathcal{J}_j$ , the following

holds: either  $\mathcal{I}_j = L$  and  $\mathcal{J}_j = R$  and the number of  $L$ 's in  $\mathcal{I}_i$ ,  $0 \leq i < j$  is odd, or  $\mathcal{I}_j = R$  and  $\mathcal{J}_j = L$  and the number of  $L$ 's in  $\mathcal{I}_i$ ,  $0 \leq i < j$  is even.

Note that  $f_\mu^j(x)$  is decreasing at  $x$  (and thus changes the order of points close to  $x$ ), precisely if the number of  $L$ 's in  $\mathcal{I}_i(x)$ ,  $0 \leq i \leq j$  is odd. From this one deduces that  $\mathcal{I}(x) < \mathcal{I}(y)$  implies  $x < y$ , so that itineraries of points reflect the position on the interval. This observation immediately gives a result on the order of homoclinic bifurcations. First note that if one lets  $\mu$  increase, a horseshoe is created (an interval map is said to have a horseshoe if the interval is mapped twice over itself). From the above considerations one concludes that for each  $\mathcal{I} < \mathcal{J}$ , there are parameter values  $\mu^1 < \mu^2$ , so that 0 is a periodic point both for  $f_{\mu^1}$  and for  $f_{\mu^2}$ , and such that  $\mathcal{I}(0) = \mathcal{I}$  for  $\mu = \mu^1$  and  $\mathcal{I}(0) = \mathcal{J}$  for  $\mu = \mu^2$ .

If one further has a monotonicity property of the homoclinic bifurcations, saying that the value of  $\mu$  for which 0 is periodic with some prescribed itinerary, is unique, then this fully describes the order of homoclinic bifurcations.

Considering the change in itinerary under the action of the renormalization operator, see [18], one sees that the first homoclinic bifurcations are of periodic points with itineraries

$$(L)^\infty, (LR)^\infty, (LRL)^\infty, (LRLRL)^\infty,$$

in this order. Observe that the periods are powers of two. For each itinerary, the following itinerary is obtained by taking the block of symbols which is periodically repeated, putting two of these blocks behind each other, changing the last symbol of the new obtained block and then repeating this block periodically. The ordering is the same as found in symbolic dynamics for smooth unimodal maps [27].

There are various such sequences of homoclinic bifurcations. Indeed, if  $U$  is a block of symbols containing an even number of  $L$ 's, then there is a sequence of subsequent homoclinic bifurcations with the following itineraries:

$$(UR)^\infty, (UL)^\infty, (ULUR)^\infty, (ULURUL)^\infty,$$

and so on using the same rule as above. The resulting periods are powers of two times the number of symbols in  $UR$ . A similar sequence of subsequent homoclinic bifurcations exists for blocks of symbols  $U$  containing an odd number of  $L$ 's. Here the order is

$$(UL)^\infty, (UR)^\infty, (URUL)^\infty, (URULUR)^\infty,$$

and so on.

### 3.3 The bifurcation set

The bifurcation set of the family  $\{f_{p,r}\}$  in the  $(p, r)$ -parameter plane, near a point in  $\mathbf{IF}_n$ , is expected to be the same as for homoclinic-doubling bifurcations, see Figure 1 in the introduction. It seems to be hard, though, to prove that these bifurcations in  $\mathbf{IF}_n$  unfold generically in the family  $\{f_{p,r}\}$ . In this direction, we have the following information on the homoclinic bifurcation values near points in  $\mathbf{IF}_n$ .

**Lemma 3.1** *Let  $(p, r) = (p_n, p_n) \in \mathbf{IF}_n$ . Then  $\mathbf{H}_n$  in a small neighborhood of  $(p_n, p_n)$  is a smooth curve, tangent to the diagonal at  $(p_n, p_n)$ .*

PROOF. We use the implicit function theorem. Let  $\varphi(p, r) = f_{p,r}^n(0)$ . Observe that  $\varphi$  vanishes on  $\mathbf{H}_n$ , see (3.3). Clearly we have  $\varphi(p_n, p_n) = 0$ . Note that  $\varphi(p, r)$  is a smooth function for  $(p, r)$  near  $(p_n, p_n)$ , since  $f_{p_n, p_n}^i(0) \neq 0$ ,  $1 \leq i \leq n-1$ . We compute the partial derivatives of  $\varphi$ .

$$\begin{aligned} \frac{\partial \varphi}{\partial p}(p, r) &= \frac{\partial f_{p,r}}{\partial x}(f_{p,r}^{n-1}(0)) \cdot \frac{\partial}{\partial p} \{f_{p,r}^{n-1}(0)\} \\ &\quad + \frac{\partial f_{p,r}}{\partial p}(f_{p,r}^{n-1}(0)). \end{aligned}$$

Since  $f_{p_n, p_n}^{n-1}(0) = 1$ ,  $\frac{\partial f_{p_n, p_n}}{\partial x}(1) = 0$ , and  $\frac{\partial f_{p,r}}{\partial p}(x) = 1$ , we have

$$\frac{\partial \varphi}{\partial p}(p, r) = 1.$$

Similarly, since  $\frac{\partial f_{p,r}}{\partial r}(1) = -1$ , we have

$$\frac{\partial \varphi}{\partial r}(p, r) = -1.$$

Therefore, the gradient of  $\varphi$  at  $(p_n, p_n)$  is  $(1, -1)$  which is non-zero and is perpendicular to the diagonal. The assertion follows.  $\square$

Under the assumption that bifurcations unfold generically, the simplest consistent way to connect bifurcation curves in a cascade of inclination-flips in  $\mathbf{IF}_{2n}$ , seems to be as depicted in Figure 4. Such a bifurcation picture is also indicated by numerics done in [23].

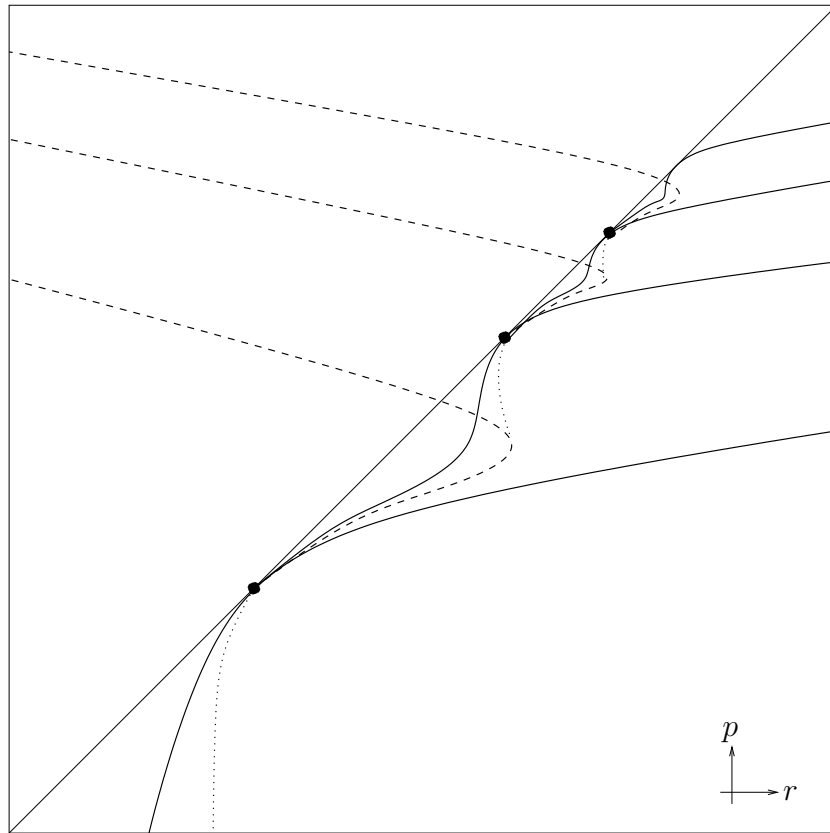

- ..... Saddle-node bifurcations of periodic orbits
- Period-doubling bifurcations of periodic orbits
- Homoclinic bifurcations

Figure 4: This figure gives an impression of the expected bifurcation set of  $\{f_{p,r}\}$  in the parameter plane. The thick dots indicate three subsequent inclination-flip bifurcations. Inclination-flips occur on the diagonal  $p = r$  in the parameter plane. Along lines  $p - r = d$  with  $d > 0$ , there are cascades of period-doubling bifurcations. Along lines  $p - r = d$  with  $d < 0$ , one finds cascades of homoclinic bifurcations.

## 4 Dynamics of the rescaled return map

In this section we collect two results on the dynamics of the rescaled Poincaré return map  $\Psi_{\varepsilon,p,r}$ , which we derived in Section 2. Both results will be used in the proof of the our main theorem, Theorem 2.4.

Let  $\{X_\gamma\}$  be as in the statement of Theorem 2.4; for other notation see Proposition 2.5.

**Lemma 4.1** *Let  $(\varepsilon, p, r) \in (0, \varepsilon_0] \times \mathbb{I} \times \mathbb{J}$ . Then, with  $\gamma = \sigma_p(\varepsilon, p, r)$ , the vector field  $X_\gamma$  has no orbit-flip homoclinic orbit.*

PROOF. Since  $p$  belongs to a compact interval, (2.15) yields that, for some  $k_1 > 0$ ,

$$|\omega| \geq k_1 \varepsilon^{\alpha-\beta}. \quad (4.1)$$

Putting  $x_u = \varepsilon x/p$  from (2.16) in (2.11), one obtains

$$|\Phi^s(x_s, \varepsilon x/p; \gamma) - \omega| < O(\varepsilon^\beta), \quad (4.2)$$

as  $\varepsilon \rightarrow 0$ , uniformly in  $x_s$  from a compact interval. From (4.1) and (4.2) we get

$$|\Phi^s(x_s, \varepsilon x/p; \gamma)| > k_1 \varepsilon^{\alpha-\beta} - O(\varepsilon^\beta),$$

as  $\varepsilon \rightarrow 0$ . Since for small values of  $\gamma$ ,  $\beta(\gamma) > \alpha(\gamma) - \beta(\gamma)$ , it follows that for  $\varepsilon$  small enough,  $|\Phi^s(x_s, \varepsilon x/p; \gamma)| > 0$ . This implies that the unstable manifold of the singularity cannot be contained in the strong stable manifold, which means that orbit-flip homoclinic orbits do not occur in this region of the parameter space.  $\square$

### 4.1 Existence of invariant foliations

Recall that the rescaled return map  $\Psi_{\varepsilon,p,r}$  is considered on a bounded domain  $\Delta$  of the form

$$\Delta = \{(x, y); 0 < x \leq A_x, |y| \leq A_y\},$$

for parameter values  $(\varepsilon, p, r)$  from  $(0, \varepsilon_0] \times \mathbb{I} \times \mathbb{J}$ . An invariant strong stable foliation of  $\Psi_{\varepsilon,p,r}$  on  $\Delta$  is a foliation  $\mathfrak{F}$  of  $\Delta$  with one dimensional leaves

satisfying  $\Psi_{\varepsilon,p,r}(\mathfrak{F}_q) \subset \mathfrak{F}_{\Psi_{\varepsilon,p,r}(q)}$  and  $\|\Psi_{\varepsilon,p,r}(q_1) - \Psi_{\varepsilon,p,r}(q_2)\| \leq \lambda\|q_1 - q_2\|$  if  $q_2 \in \mathfrak{F}_{q_1}$ , for some  $\lambda < 1$ . The existence of an invariant strong stable foliation enables a reduction to a one dimensional map, by identifying points on the same leaf of the foliation. The range of  $\varepsilon$ -values for which this holds however, is not proved to be uniform in  $p, r$ ; the value of  $\bar{\varepsilon}(p, r)$  in the formulation of the lemma below goes to 0 if we let  $p-r$  go to 0. Invariant foliations have been constructed at various places, for constructions comparable to the following, see e.g. [33], [18].

**Lemma 4.2** *There is a continuous positive function  $\bar{\varepsilon}(p, r)$ , defined for  $p < r$  and with  $\bar{\varepsilon}(p, r) \rightarrow 0$  as  $r-p \rightarrow 0$ , so that  $\Psi_{\varepsilon,p,r}$  possesses an invariant strong stable foliation on  $\Delta$  for  $p < r$  and  $\varepsilon < \bar{\varepsilon}(p, r)$ .*

PROOF. For convenience we suppress the dependence of the rescaled return map on  $\varepsilon, p, r$  from the notation and write  $\Psi$  for the rescaled return map. From Proposition 2.5,  $\Psi$  is of the form

$$\Psi(x, y) = (f(x), 0) + (h_1(x, y), h_2(x, y)),$$

where

$$f(x) = p + \frac{r}{1-\beta} (\beta x^\alpha - x^\beta) \quad (4.3)$$

and, for  $i = 1, 2$ ,  $h_i$  satisfies

$$|h_i(x, y)|, \left| x \frac{\partial h_i}{\partial x}(x, y) \right|, \left| \frac{\partial h_i}{\partial y}(x, y) \right| \leq C_\varepsilon |x|^\beta, \quad (4.4)$$

for some  $C_\varepsilon > 0$  with  $C_\varepsilon \rightarrow 0$  as  $\varepsilon \rightarrow 0$ . Note that  $\Psi(x, y)$  is not defined if  $x = 0$ .

We will construct a strong stable foliation on  $\Delta$ . We may assume that  $A_x$  is large enough so that both  $A_x > p$  and  $f(A_x) > A_x$ , for all  $p \in \mathbb{I}$ . Let us describe the idea of the construction of the strong stable foliation. Let  $\tau = \Delta \cap \Psi^{-1}(\{0\} \times [-A_y, A_y])$  and  $\rho = \Delta \cap \Psi^{-1}(\{A_x\} \times [-A_y, A_y])$ ; we will see that  $\tau$  bounds a strip  $T$  and  $\rho$  together with  $(0, A_x] \times \{A_y\}$  bounds a strip  $R$  in  $\Delta$ , as indicated in Figure 5. The image  $\Psi^{-1}(\Delta)$  intersects  $T \cup R$  only in the boundary curves  $\tau \cup \rho$ . Take a trial foliation  $\mathfrak{F}$  on the closure of  $\Delta$ , containing  $\{0\} \times [-A_y, A_y]$ ,  $\{A_x\} \times [-A_y, A_y]$ ,  $\tau$  and  $\rho$  as leaves. We claim that, for a suitable choice of  $\mathfrak{F}$ , a strong stable foliation of  $\Psi$  on  $\Delta$  is obtained as the limit of  $\bigcup_{0 \leq n \leq m} \Psi^{-n}(\mathfrak{F}|_{T \cup R}) \cup \Psi^{-m}(\mathfrak{F})$  as  $m \rightarrow \infty$ .

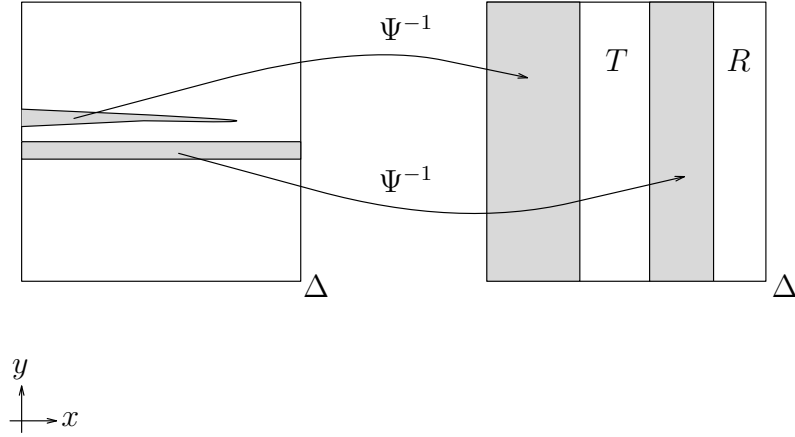

Figure 5: In the left picture the domain of  $\Psi^{-1}$  is indicated, as a subset of  $\Delta = (0, A_x] \times [-A_y, A_y]$ . The right picture depicts the image  $\psi^{-1}(\Delta)$ .

Observe that  $\lim_{x \rightarrow 0} \Psi(x, y)$  is a point whose coordinates do not depend on  $y$ ; it is in fact the first intersection of the unstable manifold of the singularity of the vector field with  $\Delta$ . Denote this point by  $P$ . Observe that  $\Psi^{-1}$  is not defined at  $P$ . Let

$$C_s(x, y) = \{(u, v) \in T_{(x,y)}\Delta; |u| \leq s|v|\},$$

where  $(u, v)$  are the natural coordinates on  $T_{(x,y)}\Delta$ . Below we show that, for  $\varepsilon$  small, a function  $s(x, y)$  exists with  $0 < s(x, y) \leq 1$  and  $s(x, y) \rightarrow 0$  as  $x \rightarrow 0$ , so that

$$D\Psi^{-1}(\Psi(x, y))C_1(\Psi(x, y)) \subset C_{s(x,y)}(x, y). \quad (4.5)$$

This means that the cone field  $\{C_{s(x,y)}\}$  is invariant under  $D\Psi^{-1}$ . For the moment, we assume that (4.5) holds. If  $\varepsilon = 0$ , because  $f(A_x) > 0$ , the equation  $f(x) = 0$  has two solutions, both in  $(0, A_x)$ . From this and (4.5) it follows that, for  $\varepsilon$  small enough,  $\tau$  consists of two curves intersecting  $\partial\Delta$  in  $(0, A_x] \times \{-A_y\}$  and  $(0, A_x] \times \{A_y\}$ . Note that  $T_{(x,y)}\tau \subset C_1(x, y)$ . Similarly, using  $f(A_x) > A_x > p$ , if  $\varepsilon = 0$ , the equation  $f(x) = A_x$  has one solution, which is contained in  $(0, A_x)$ . From this and (4.5), for  $\varepsilon$  small,  $\rho$  is a curve intersecting  $\partial\Delta$  in  $(0, A_x] \times \{-A_y\}$  and  $(0, A_x] \times \{A_y\}$ . Note that  $T_{(x,y)}\rho \subset C_1(x, y)$ . The strips  $T$  and  $R$  are therefore well defined. We have that



$\Psi^{-1}(\Delta) \cap T = \tau$  and  $\Psi^{-1}(\Delta) \cap R = \rho$ . Choose a trial foliation  $\mathfrak{F}$  on the closure of  $\Delta$  as above, so containing  $\{0\} \times [-A_y, A_y]$ ,  $\{A_x\} \times [-A_y, A_y]$ ,  $\tau$  and  $\rho$  as leaves, satisfying in addition  $T_{(x,y)}\mathfrak{F}_{(x,y)} \subset C_1(x, y)$ . From (4.5) we conclude that the foliation  $\mathfrak{F}^m$  given by

$$\mathfrak{F}^m = \bigcup_{0 \leq n \leq m} \Psi^{-n}(\mathfrak{F}|_{R \cup T}) \cup \Psi^{-m}(\mathfrak{F}),$$

is a continuous foliation on  $\Delta$ , satisfying

$$T_{(x,y)}\mathfrak{F}^m_{(x,y)} \subset C_{s(x,y)}(x, y). \quad (4.6)$$

In order to show that  $\mathfrak{F}^m$  converges to a continuous foliation as  $m \rightarrow \infty$ , it suffices to show that for each  $(x, y) \in \Delta$ ,  $(x, y) \mapsto T_{(x,y)}\mathfrak{F}^m_{(x,y)}$  converges to a continuous line bundle over  $\Delta$ . Let  $(x, y, \sigma) \mapsto (\Psi^{-1}(x, y), \Sigma(x, y, \sigma))$  be the induced map on  $\Delta \times \mathcal{L}(\mathbb{R}, \mathbb{R})$ . That is,  $\Sigma(x, y, \sigma) = \nu$  where graph  $\nu = D\Psi^{-1}(x, y)\text{graph } \sigma$ . This yields

$$\Sigma(x, y, \sigma) = \frac{a(x, y)\sigma + b(x, y)}{c(x, y)\sigma + d(x, y)}, \quad (4.7)$$

where

$$D\Psi^{-1}(x, y) = \begin{pmatrix} a(x, y) & b(x, y) \\ c(x, y) & d(x, y) \end{pmatrix}.$$

Below we will show that  $\Sigma$  contracts distances in the fibers: there is  $k < 1$  so that for all  $(x, y) \in \Delta$ ,

$$|\Sigma(x, y, \sigma_1) - \Sigma(x, y, \sigma_2)| \leq k|\sigma_1 - \sigma_2|. \quad (4.8)$$

It is standard to derive Lemma 4.2 from (4.8), using (4.6) to assure that the limit foliation is continuous at  $\{x = 0\}$ , compare [16], [18].

It remains to show (4.5) and (4.8). Note that

$$D(f, 0) = \begin{pmatrix} -\frac{r\beta}{1-\beta}x^{\beta-1} + \frac{r\beta\alpha}{1-\beta}x^{\alpha-1} & 0 \\ 0 & 0 \end{pmatrix}. \quad (4.9)$$

From  $D\Psi = D(f, 0) + D(h_1, h_2)$ , using (4.4) and  $2\beta > 1$ , it follows that the determinant of  $D\Psi(x, y)$  goes to 0 as  $\varepsilon$  goes to 0, uniformly in  $(x, y)$ . (In fact, one can show that the determinant of  $D\Psi(x, y)$  is small of order  $\varepsilon^\beta$ ,

uniformly in  $(x, y)$ .) Furthermore, for each  $p, r$ , there is a constant  $c > 0$  so that for  $\varepsilon$  small enough and for all  $(x, y)$ , the trace of  $D\Psi(x, y)$  is larger than  $c$ . For  $c$  one can take e.g. one half times the minimum of  $|f'(x)|$  over those  $x$  for which  $f(x) \geq 0$ . From these estimates on the determinant and the trace of  $D\Psi(x, y)$ , one obtains that  $D\Psi(x, y)$  has eigenvalues  $\lambda_i(x, y)$ ,  $i = 1, 2$ , with  $\lambda_2(x, y) \rightarrow 0$  as  $\varepsilon \rightarrow 0$  and  $|\lambda_1(x, y)| \geq c$  for some constant  $c > 0$ , if  $\varepsilon$  is small enough. Furthermore,  $\lambda_1(x, y) \rightarrow \infty$  as  $x \rightarrow 0$ , since the trace of  $D\Psi(x, y)$  goes to  $\infty$  as  $x \rightarrow 0$ .

Using (4.9) and (4.4), one obtains that for each  $\delta > 0$ , there exists  $\hat{\varepsilon} > 0$  so that for all  $\varepsilon$  with  $0 < \varepsilon < \hat{\varepsilon}$ , a unit eigenvector  $v_i(x, y)$  corresponding to  $\lambda_i(x, y)$ , is within  $\delta$  distance of  $(1, 0)$  for  $i = 1$  and of  $(0, 1)$  for  $i = 2$ . Also,  $v_2(x, y) \rightarrow (0, 1)$  as  $x \rightarrow 0$ , for all small  $\varepsilon$ .

Note that  $D\Psi^{-1}(x, y)$  has eigenvalues  $1/\lambda_i(\Psi^{-1}(x, y))$ ,  $i = 1, 2$ . From the above it follows that  $1/\lambda_2(\Psi^{-1}(x, y)) \rightarrow \infty$  as  $\varepsilon \rightarrow 0$  and  $1/\lambda_1(\Psi^{-1}(x, y)) \leq 1/c$  for sufficiently small values of  $\varepsilon$ . The eigenvectors of  $D\Psi^{-1}(x, y)$  equal those of  $D\Psi(\Psi^{-1}(x, y))$ . With  $Q = (v_1(\Psi^{-1}(x, y)) \ v_2(\Psi^{-1}(x, y)))$ , we have

$$D\Psi^{-1}(x, y) = Q \begin{pmatrix} \frac{1}{\lambda_1(x, y)} & 0 \\ 0 & \frac{1}{\lambda_2(x, y)} \end{pmatrix} Q^{-1}. \quad (4.10)$$

Using that  $Q$  and  $Q^{-1}$  are close to the identity matrix, an easy estimate on (4.7) yields (4.8).

We have seen that  $\lambda_1(x, y) \rightarrow \infty$  as  $x \rightarrow 0$ , for all small  $\varepsilon$ . So  $1/\lambda_1(x, y) \rightarrow 0$  as  $(x, y) \rightarrow P$  within the domain of  $\Psi^{-1}$ . Now (4.5) follows from this and the fact that  $v_2(x, y) \rightarrow (0, 1)$  as  $x \rightarrow 0$ , for all small  $\varepsilon$ .

Finally, observe that since the bound  $c$  must be chosen smaller than the infimum of  $|f'(x)|$  over  $x > 0$  with  $f(x) \geq 0$ ,  $c$  will be small for parameter values  $(p, r)$  with  $p - r$  close to 0. Therefore,  $\bar{\varepsilon}$  from the formulation of the lemma will go to 0 as  $p - r \rightarrow 0$ .  $\square$

Let  $P_{\varepsilon, p, r} = \lim_{d \downarrow 0} \Psi_{\varepsilon, p, r}(d, y)$ . Note that  $P_{\varepsilon, p, r}$  does not depend on  $y$ ;  $P_{\varepsilon, p, r}$  is in fact the first intersection of the unstable manifold  $W^u(O)$  with the cross section  $S$ , in rescaled coordinates. An  $n$ -homoclinic orbit of  $X_{\sigma_p(\varepsilon, p, r)}$  occurs if  $\Psi_{\varepsilon, p, r}^{n-1}(P_{\varepsilon, p, r})$  is contained in  $\{(x, y); x = 0\}$ . The following lemma shows that homoclinic orbits of  $X_{\sigma_p(\varepsilon, p, r)}$  are confined to a small tubular neighborhood of the orbit-flip homoclinic orbit at resonance.

**Lemma 4.3** *For  $A_x$  large enough and for all  $(\varepsilon, p, r) \in (0, \varepsilon_0] \times \mathbb{I} \times \mathbb{J}$ , there is a constant  $0 < B_y < A_y$  and a function  $\tau : [-A_y, A_y] \rightarrow (0, A_x)$  so that, if  $\Psi_{\varepsilon, p, r}^{n-1}(P_{\varepsilon, p, r}) \in \{(x, y); x = 0\}$ , then  $\Psi_{\varepsilon, p, r}^i(P_{\varepsilon, p, r})$  is contained in  $\{(x, y); |y| \leq B_y, 0 < x < \tau(y)\}$  for all  $i, 0 \leq i < n - 1$ .*

PROOF. Let  $q_{p,r}$  denote the fixed point of  $f_{p,r}$  with  $Df_{p,r}(q_{p,r}) > 1$ . For  $\varepsilon$  small enough  $\Psi_{\varepsilon, p, r}$  has a hyperbolic saddle fixed point  $Q_{\varepsilon, p, r}$  that is the continuation of  $q_{p,r}$ . As in the proof of Lemma 4.2, one shows that the stable manifold of  $Q_{\varepsilon, p, r}$  is the graph of a function  $\tau : [-A_y, A_y] \rightarrow (0, A_x)$  (if  $A_x$  is large enough). Write  $Z_{\tau, C} = \{(x, y); |y| \leq C, 0 < x < \tau(y)\}$ . Clearly, if  $P_{\varepsilon, p, r}$  is not contained in  $Z_{\tau, A_y}$ , then  $\Psi^i(P_{\varepsilon, p, r}) \notin Z_{\tau, A_y}$ , for all positive integers  $i$ . If  $P_{\varepsilon, p, r} \in Z_{\tau, A_y}$  we have  $\Psi_{\varepsilon, p, r}(Z_{\tau, B_y}) \subset Z_{\tau, B_y}$  for some  $B_y < A_y$ . This proves the lemma.  $\square$

## 5 Continuation of homoclinic bifurcations

In the introduction we mentioned the central role a continuation theory for homoclinic orbits plays in the demonstration of our main result. We do not develop such a theory in its fullest generality, but develop it as appropriate for our needs. Our continuation theory for homoclinic orbits is reminiscent of the continuation theory for periodic orbits as constructed in [3], [2]. The notion of virtual length of a homoclinic orbit and the definition of being continuable are inspired by the corresponding notions for continuing periodic orbits in these works. For generic families, where homoclinic bifurcations unfold generically, a pathfollowing result for homoclinic orbits was obtained by B. Fiedler in [11]. Following this paper, we consider an index of periodic orbits created in the homoclinic bifurcations and use it to continue homoclinic orbits.

We discuss generic families in the next subsection, in this first subsection we present the statements of our continuation theory for homoclinic orbits.

Let  $\mathfrak{X}$  be the set of smooth vector fields on  $\mathbb{R}^3$ , equipped with the weak Whitney topology. Consider the set  $\mathfrak{X}_2$  of smooth two parameter families of smooth vector fields on  $\mathbb{R}^3$ . Let  $\{X_\lambda\}$  be a two-parameter family of vector fields from  $\mathfrak{X}_2$ , depending on a parameter  $\lambda \in \mathbb{R}^2$ .

Let  $\mathcal{P}$  be the set of bounded closed subsets of  $\mathbb{R}^3$ , equipped with the Hausdorff metric. Let

$$G = \left\{ (\mu, h) \in \mathbb{R}^2 \times \mathcal{P}; \begin{array}{l} h \text{ is the union of a singularity and} \\ \text{a homoclinic orbit of } X_\mu \end{array} \right\}. \quad (5.1)$$

For  $(\mu, h) \in G$ , let  $l(\mu, h)$  denote the length of  $h$  (length here means arclength). For simplicity we assume  $l(\mu, h)$  is finite, which is guaranteed, for instance, if one considers orbits homoclinic to a hyperbolic singularity.

**Definition 5.1** *Let  $(\mu, h) \in G$  be as above. We say that  $k$  is a virtual length of  $(\mu, h)$ , if there exists a sequence of perturbations  $\{Y_\lambda^i\}$  of  $\{X_\lambda\}$  with  $\{Y_\lambda^i\} \rightarrow \{X_\lambda\}$  as  $i \rightarrow \infty$  so that  $\{Y_\lambda^i\}$  possesses a homoclinic orbit  $h_i$  at parameter values  $\mu_i$  with  $\mu_i \rightarrow \mu$ ,  $h_i \rightarrow h$  in the Hausdorff topology and  $l(\mu_i, h_i) \rightarrow k$  as  $i \rightarrow \infty$ .*

We write  $\tau(\mu, h)$  for the set of virtual lengths of  $(\mu, h)$ . In Section 5.1 we calculate the virtual lengths of different codimension-one and codimension-two homoclinic orbits.

Let  $(\mu, h) \in G$  so that  $h$  is the union of a homoclinic orbit and a hyperbolic singularity. Write  $\Gamma$  for the connected component of  $G$  containing  $(\mu, h)$ . We call  $(\mu, h)$  globally continuable if either

- $\Gamma \setminus \{(\mu, h)\}$  is connected

or each component  $C$  of  $\Gamma \setminus \{(\mu, h)\}$  satisfies at least one of the following conditions:

- $C$  is unbounded
- there exists a sequence  $(\nu_i, g_i) \in C$  so that  $\sup_i \tau(\nu_i, g_i) = \infty$ .
- there exists a sequence  $(\nu_i, g_i) \in C$  so that, as  $i \rightarrow \infty$ ,  $\nu_i \rightarrow \nu$  and  $g_i$  converges in the Hausdorff topology to a closed invariant set containing either a nonhyperbolic singularity, or more than two orbits.

Note that the closure of a homoclinic orbit consists of two orbits. By a closed invariant set containing more than two orbits, one can think of a set containing two homoclinic orbits or a heteroclinic cycle.

Suppose that  $(\mu, h) \in G$  is a generically unfolding codimension-one homoclinic orbit with  $\tau(\mu, h) = \{l(\mu, h)\}$ . In the next subsection we explain what is meant by generically unfolding and codimension-one, here we use the following property  $(\mu, h)$  as above satisfies: there is a sequence  $\mu_i$  of parameter values converging to  $\mu$  and a periodic orbit  $h_i$  of  $X_{\mu_i}$  converging to  $h$  in the Hausdorff topology as  $i \rightarrow \infty$ . For all sufficiently large  $i$ ,  $h_i$  is unique and its unstable manifold  $W^u(h_i)$  is either orientable or nonorientable. Note

that an unstable manifold which is either one or three dimensional is always orientable. Define

$$\phi(\mu, h) = \begin{cases} 0, & \text{if } W^u(h_i) \text{ is nonorientable for large } i, \\ 1, & \text{if } W^u(h_i) \text{ is orientable for large } i. \end{cases} \quad (5.2)$$

If  $W^u(h_i)$  is two dimensional, there exists a two dimensional center manifold  $W^{s,u}(h)$  of  $h$  [38], [18]. Then  $\phi(\mu, h) = 0, 1$  if  $W^{s,u}(h)$  is nonorientable, orientable respectively. It is thus possible to define  $\phi$  using  $X_\mu$  alone.

For any  $(\mu, h) \in G$ , we let  $\phi(\mu, h) = 1$  if the virtual lengths of  $(\mu, h)$  are bounded and there exists a sequence of families  $\{Y_\lambda^i\} \in \mathfrak{X}_2$  with  $\{Y_\lambda^i\} \rightarrow \{X_\lambda\}$  as  $i \rightarrow \infty$  and  $\{Y_\lambda^i\}$  possesses a generically unfolding homoclinic orbit  $h_i$  of codimension-one at parameter values  $\mu_i$  with  $\mu_i \rightarrow \mu, h_i \rightarrow h$  in the Hausdorff topology as  $i \rightarrow \infty, \phi(\mu_i, \tau_i) = 1$ . For all other  $(\mu, h) \in G$ , we let  $\phi(\mu, h) = 0$ . Denote

$$G_1 = \{(\mu, h) \in G; \phi(\mu, h) = 1\}. \quad (5.3)$$

The notion of continuability of homoclinic orbits  $(\mu, h)$  in  $G_1$  is as follows. Let  $(\mu, h) \in G_1$  so that  $h$  is the union of a homoclinic orbit and a hyperbolic singularity. Write  $\Gamma_1$  for the connected component of  $G_1$  containing  $(\mu, h)$ . We call  $(\mu, h)$  globally I-continuable if either

- $\Gamma_1 \setminus \{(\mu, h)\}$  is connected

or each component  $C_1$  of  $\Gamma_1 \setminus \{(\mu, h)\}$  satisfies at least one of the following conditions:

- $C_1$  is unbounded
- there exists a sequence  $(\nu_i, g_i) \in C_1$  so that  $\sup_i \tau(\nu_i, g_i) = \infty$  or so that  $(\nu_i, g_i) \rightarrow (\nu, g) \in G$  as  $i \rightarrow \infty$  with  $(\nu, g)$  possessing unbounded virtual lengths.
- there exists a sequence  $(\nu_i, g_i) \in C_1$  so that, as  $i \rightarrow \infty, \nu_i \rightarrow \nu$  and  $g_i$  converges in the Hausdorff topology to a closed invariant set containing either a nonhyperbolic singularity, or more than two orbits.

The following continuation theorem will be proved in Section 5.2.

**Theorem 5.2** *Let  $(\kappa, \gamma) \in G_1$  be a generically unfolding codimension-one homoclinic orbit of  $\{X_\lambda\}$ . Then  $(\kappa, \gamma)$  is globally I-continuable.*

## 5.1 Generic families

We start with a brief discussion of the possible codimension-one and codimension-two homoclinic orbits. We give the virtual lengths of these homoclinic orbits. Let  $\{X_\lambda\} \in \mathfrak{X}_2$  and let  $G, G_1$  be as defined in (5.1) respectively (5.3).  $(\mu, h) \in G$  is called a codimension-one homoclinic orbit if  $h$  is homoclinic to a hyperbolic singularity  $p(\mu, h)$  and the following conditions are fulfilled. Denote by  $-\alpha, -\beta, \gamma$  the eigenvalues of  $DX_\mu(p(\mu, h))$ . By changing the time parametrization of solutions, we may assume that  $\gamma = 1$  and  $\operatorname{Re} \alpha \geq \operatorname{Re} \beta > 0$ .  $(\mu, h) \in G$  is called a homoclinic orbit of codimension-one if the following conditions are satisfied.

- (1)  $\alpha \neq \beta$ ,
- (2) if  $\alpha, \beta \in \mathbb{C} \setminus \mathbb{R}$ , then  $\operatorname{Re} \beta \neq 1$ ,
- (3) if  $\alpha, \beta \in \mathbb{R}$ , then
  - (a)  $\beta \neq 1$ ,
  - (b)  $h \not\subset W^{ss}(p(\mu, h))$ ,
  - (c)  $W^{s,u}(p(\mu, h))$  intersects  $W^{ss,s}(p(\mu, h))$  transversally along  $h$ .

Here  $W^{ss}(p(\mu, h))$  denotes the one dimensional strong stable manifold of  $p(\mu, h)$ , well defined if  $\alpha, \beta \in \mathbb{R}$  and  $\alpha \neq \beta$ . Furthermore,  $W^{ss,s}(p(\mu, h))$  is the two dimensional stable manifold of  $p(\mu, h)$  and  $W^{s,u}(p(\mu, h))$  is a two dimensional center unstable manifold of  $p(\mu, h)$ , see also [18]. We denote by  $W^u(p(\mu, h))$  the one dimensional unstable manifold of  $p(\mu, h)$ .

For  $\lambda$  near  $\mu$ , let  $p(\lambda, h)$  denote the hyperbolic singularity near  $p(\mu, h)$ . All invariant manifolds defined above, exist for  $\lambda$  near  $\mu$ . We say that a homoclinic orbit  $(\mu, h)$  of codimension-one unfolds generically if  $\bigcup_\lambda(\lambda, W^u(p(\lambda, h)))$  intersects  $\bigcup_\lambda(\lambda, W^{ss,s}(p(\lambda, h)))$  transversally in  $\mathbb{R}^2 \times \mathbb{R}^3$  along  $(\mu, h)$ .

If  $(\mu, h) \in G$  is a homoclinic orbit of codimension-one, then  $\tau(\mu, h) = \{l(\mu, h)\}$  with one exception: if  $\alpha = \bar{\beta}$  and  $\operatorname{Re} \beta < 1$ , then  $(\mu, h)$  has unbounded virtual lengths [40], [13], [14]. Near a generically unfolding homoclinic orbit  $(\mu, h)$  of codimension-one with  $\tau(\mu, h) = \{l(\mu, h)\}$ ,  $G$  is a curve embedded in  $\mathbb{R}^2 \times \mathcal{P}$ .

Next we discuss to some extent codimension-two homoclinic orbits. We discuss only homoclinic orbits that are homoclinic to a hyperbolic singularity. In particular a list is obtained of codimension-two homoclinic orbits,

homoclinic to a hyperbolic singularity, with bounded virtual lengths. For a precise definition of generic unfolding for codimension-two homoclinic orbits we refer to the corresponding literature.  $(\mu, h) \in G$  is a homoclinic orbit of codimension-two if precisely one of the conditions for being of codimension-one does not apply (in some cases additional nondegeneracy conditions should hold). This yields the following list.

- (1) does not hold:  $\alpha = \beta$ .  $(\mu, h)$  has unbounded virtual lengths if  $\beta < 1$  since an arbitrarily small perturbation of  $X_\mu$  yields a vector field so that the linearization at the singularity has two complex conjugate eigenvalues. If  $\beta > 1$ ,  $\tau(\mu, h) = \{l(\mu, h)\}$ . In fact, if  $(\mu, h)$  is generically unfolding,  $G$  is near  $\mu$  a curve on which  $\phi = 1$ . This is easily deduced from the fact that a Poincaré return map on a cross section is a contraction, compare [12].
- (2) does not hold:  $\alpha, \beta \in \mathbb{C} \setminus \mathbb{R}$  and  $\operatorname{Re} \beta = 1$ .  $(\mu, h)$  has unbounded virtual lengths since an arbitrarily small perturbation would make  $\operatorname{Re} \beta < 1$ .
- (3a) does not hold:  $\beta = 1$ . The virtual lengths of  $(\mu, h)$  are bounded by  $2l(\mu, h)$ . Assuming an additional nondegeneracy condition holds, there are two possible bifurcation diagrams [6], see also [21], [36]. In one case,  $\tau(\mu, h) = \{l(\mu, h)\}$ . Here, if  $(\mu, h)$  is generically unfolding, then near  $(\mu, h)$ ,  $G$  is a curve along which  $\phi = 1$ . In the other case  $\tau(\mu, h) = \{l(\mu, h), 2l(\mu, h)\}$ . Near  $(\mu, h)$ , if  $(\mu, h)$  is generically unfolding,  $G$  consists of three curves branching at  $(\mu, h)$ . One curve consists of doubled homoclinic orbits with approximately twice the length of  $(\mu, h)$ . Inspection of the bifurcation diagram reveals that near  $(\mu, h)$ ,  $G_1$  is a curve containing the curve of doubled homoclinic orbits and one of the other curves branching at  $(\mu, h)$ , as in Figure 6.
- (3b) does not hold:  $h$  is an orbit-flip homoclinic orbit. We refer to [36] for a treatment of this bifurcation problem. If  $\beta < 1$  and  $\alpha \leq 1$  the virtual lengths of  $(\mu, h)$  are unbounded. If  $\beta > 1$  and  $\alpha > 1$ , then  $\tau(\mu, h) = \{l(\mu, h)\}$ . If in this case  $(\mu, h)$  is generically unfolding, then near  $(\mu, h)$   $G$  is a curve along which  $\phi = 1$ . Finally, if  $\alpha > 1$  and  $\beta < 1$ , then  $\tau(\mu, h) = \{l(\mu, h), 2l(\mu, h)\}$ . Near  $(\mu, h)$ , if  $(\mu, h)$  is generically unfolding,  $G$  consists of three curves branching at  $(\mu, h)$ . One curve consists of doubled homoclinic orbits. By considering the bifurcation

diagram one sees that near  $(\mu, h)$ ,  $G_1$  is a curve containing the curve of doubled homoclinic orbits and one of the other curves branching at  $(\mu, h)$ . See Figure 6.

- (3c) does not hold:  $h$  is an inclination-flip homoclinic orbit. It follows from [17], [28] that  $(\mu, h)$  has unbounded virtual lengths if  $\alpha \leq 1$  or  $\beta \leq \frac{1}{2}$ . For other eigenvalue conditions,  $(\mu, h)$  has bounded virtual lengths. If  $\alpha > 1$  and  $\beta > 1$ ,  $\tau(\mu, h) = \{l(\mu, h)\}$ . In this case, if  $(\mu, h)$  is generically unfolding, then near  $(\mu, h)$   $G$  is a curve along which  $\phi = 1$  (this case is easily treated since the Poincaré return map on a cross section is a contraction). The remaining case  $\alpha > 1$  and  $\frac{1}{2} < \beta < 1$ , was studied in [21], [22], see also Theorem A.1 in Appendix A. Here,  $\tau(\mu, h) = \{l(\mu, h), 2l(\mu, h)\}$ . Near  $(\mu, h)$ , if  $(\mu, h)$  is generically unfolding,  $G$  consists of three curves branching at  $(\mu, h)$ . One curve consists of doubled homoclinic orbits. By considering the bifurcation diagram one sees that near  $(\mu, h)$ ,  $G_1$  is a curve near  $(\mu, h)$  containing the curve of doubled homoclinic orbits and one of the other curves branching at  $(\mu, h)$ . See Figure 6.

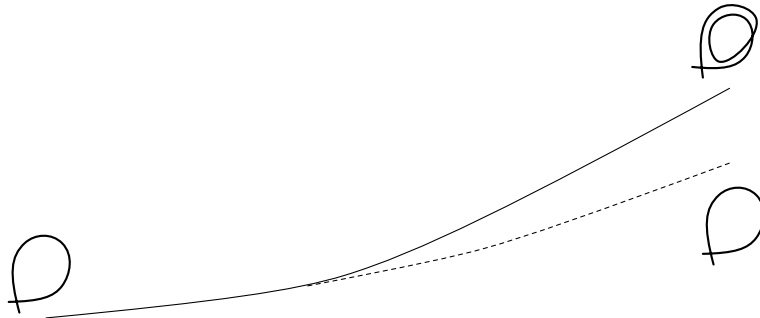

Figure 6: In all three possible cases of homoclinic-doubling, the projection of  $G$  to the parameter space  $\mathbb{R}^2$  is as depicted. The solid curve represents homoclinic orbits for which  $\phi = 1$ , on the dashed curve  $\phi = 0$ . In particular,  $\{\mu; (\mu, h) \in G_1\}$  is differentiable at each parameter value  $\mu$  on it.

It follows from the above discussion that near each generically unfolding homoclinic orbit  $(\mu, h) \in G_1$  of codimension-one or codimension-two and with bounded virtual lengths,  $G_1$  is a curve.



Before discussing generic families and stating a continuation theorem for such families, we add a remark on the bifurcation theorem as it is known for the orbit-flip, if  $\alpha > 1$  and  $\beta < 1$ , when homoclinic-doubling occurs. The bifurcation theorem in [36] states that for each integer  $n > 2$ , there is a neighborhood in the parameter plane of the orbit-flip bifurcation point, on which no  $n$ -homoclinic orbits exist. The theorem in [36] thus does not exclude the existence of  $n$ -homoclinic orbits for high  $n$ , for parameters near the orbit-flip bifurcation point. Note that this does not effect the statement that  $\tau(\mu, h) = \{l(\mu, h), 2l(\mu, h)\}$ . For the inclination-flip, with eigenvalue conditions  $\alpha > 1$  and  $\frac{1}{2} < \beta < 1$ , a similar statement was proven in [21]. In Appendix A we show that  $n$ -homoclinic orbits (and  $n$ -periodic orbits) for  $n > 2$  do not appear in the unfolding of such an inclination-flip.

Recall that a subset of a topological space is called a residual subset if it contains the intersection of countably many open and dense subsets.

**Lemma 5.3** *There is a residual subset  $\mathfrak{Y}_2$  of  $\mathfrak{X}_2$  so that all homoclinic bifurcations of  $\{X_\lambda\} \in \mathfrak{Y}_2$  are generically unfolding.*  $\square$

We omit the proof of this lemma. It can be proved in the same way as a similar result in [3], dealing with bifurcations of periodic orbits in one-parameter families of vector fields, is proved. Compare also [34], containing a prototype result for single vector fields. We call families from  $\mathfrak{Y}_2$  generic families,  $\mathfrak{Y}_2$  is in particular a dense subset of  $\mathfrak{X}_2$ .

For  $\{X_\lambda\} \in \mathfrak{Y}_2$ , along paths of generically unfolding homoclinic orbits  $(\mu, h)$  of codimension-one with  $\phi(\mu, h) = 1$ , one has an orientation as defined in [11] for generic families of vector fields. We do not define an orientation of paths of homoclinic bifurcation values since we also treat nongeneric families. Note that in our definition of I-continuable homoclinic bifurcations we do not try to continue paths of homoclinic bifurcations through e.g. heteroclinic bifurcations. Continuation through such codimension-two bifurcations seems feasible, but one would have to discuss the possible local bifurcation diagrams. Compare the definition of stratified bifurcations in [11].

## 5.2 Proof of the continuation theorem

In this section we prove Theorem 5.2. We start with a lemma that will be used frequently in the proof.

**Lemma 5.4** *Let  $\{X_\lambda^n\}$  be a sequence of families of vector fields converging to  $\{X_\lambda\}$  as  $n \rightarrow \infty$ . Suppose that  $(\mu_n, h_n)$  is a homoclinic orbit of  $X_{\mu_n}^n$ , homoclinic to a hyperbolic singularity, such that  $(\mu_n, h_n) \rightarrow (\bar{\mu}, \bar{h})$  as  $n \rightarrow \infty$ . Suppose that  $\sup_n l(\mu_n, h_n) < \infty$ . Then  $\bar{h}$  contains a nonhyperbolic singularity, or consists of more than 2 orbits, or is a homoclinic orbit of length bounded by  $\sup_n l(\mu_n, h_n)$ .*

PROOF. Denote by  $p_1$  the supremum over  $n$  of  $l(\mu_n, h_n)$ . Suppose that  $\bar{h}$  does not contain a nonhyperbolic singularity and also does not consist of more than 2 orbits. There is a neighborhood  $\mathfrak{V}$  of  $(\bar{\mu}, \bar{h})$  in  $\mathbb{R}^2 \times \mathcal{P}$  so that

- for all  $(\mu, h) \in \mathfrak{V}$ , there is a hyperbolic singularity  $p(\mu, h)$  of  $X_\mu$ , depending continuously on  $(\mu, h)$  and so that, at  $\mu = \bar{\mu}$ ,  $\bar{h}$  is homoclinic to  $p(\bar{\mu}, \bar{h})$ .

We may assume that  $p(\bar{\mu}, \bar{h})$  has a one dimensional unstable manifold  $W^u(p(\bar{\mu}, \bar{h}))$ . Let  $W^{u,+}(p(\bar{\mu}, \bar{h}))$  be the branch of  $W^u(p(\bar{\mu}, \bar{h}))$  that forms the homoclinic orbit  $\bar{h}$  of  $X_{\bar{\mu}}$ . Let  $W_{\text{loc}}^{u,+}(p(\bar{\mu}, \bar{h}))$  denote the intersection of  $W^{u,+}(p(\bar{\mu}, \bar{h}))$  with a local unstable manifold of  $p(\bar{\mu}, \bar{h})$ . We have that

- $W^{u,+}(p(\mu, h))$  can be defined for  $(\mu, h) \in \mathfrak{V}$  so that  $W_{\text{loc}}^{u,+}(p(\mu, h))$  varies continuously with  $(\mu, h)$ .

For  $n$  a positive real number, let  $W_n^{u,+}(p(\mu, h))$  be the union of piecewise smooth curves in the closure of  $W^{u,+}(p(\mu, h))$ , containing  $p(\mu, h)$  and of length bounded by  $n$ . The subset  $W_n^s(p(\mu, h))$  of the stable manifold  $W^s(p(\mu, h))$  is defined similarly.

Fix  $\delta$  small and positive. For  $(\mu, h) \in \mathfrak{V}$ , let  $D(\mu, h)$  be a small cylinder transverse to  $W^s(p(\mu, h))$  along  $\partial W_\delta^s(p(\mu, h))$ , varying continuously with  $(\mu, h)$ . Let  $D^+(\mu, h)$  be the component of  $D(\mu, h) \setminus \partial W_\delta^s(p(\mu, h))$  that is on the same side of  $W_\delta^s(p(\mu, h))$  as  $W^{u,+}(p(\mu, h))$ , let  $D^-(\mu, h)$  be the other component.

Define  $V_{p_1}^{u,+}(p(\mu, h))$  as the maximal connected compact part, containing  $p(\mu, h)$ , of  $W_{p_1}^{u,+}(p(\mu, h))$ , so that  $(\mu, V_{p_1}^{u,+}(p(\mu, h))) \in \mathfrak{V}$ . By taking a smaller neighborhood  $\mathfrak{V}$  of  $(\bar{\mu}, \bar{h})$ , if necessary, we get that

- (a) for  $(\mu, h) \in \mathfrak{V}$ ,  $p(\mu, h)$  is the only singularity contained in  $V_{p_1}^{u,+}(p(\mu, h))$ .

- (b) for  $(\mu, h) \in \mathfrak{V}$ ,  $V_{p_1}^{u,+}(p(\mu, h))$  has nonempty intersection with  $D(\mu, h)$ . Furthermore, if  $V_{p_1}^{u,+}(p(\mu, h))$  intersects  $D^-(\mu, h)$  in a point  $x$ , then all intersections of  $V_{p_1}^{u,+}(p(\mu, h))$  with  $D(\mu, h)$  are in the compact connected part of  $W^{u,+}(p(\mu, h))$  between  $p(\mu, h)$  and  $x$ .

The first item holds, for  $\mathfrak{V}$  small enough, because  $\bar{h}$  does not contain two different singularities. The second item is a consequence of this and the fact that  $\bar{h}$  is not the union of two homoclinic orbits.

Since  $V_{p_1}^{u,+}(p(\mu, h))$  does not depend continuously in the Hausdorff topology on  $(\mu, h)$ , we alter it. For  $(\mu, h) \in \mathfrak{V}$ , define the closed set  $H(\mu, h)$  as follows. If  $V_{p_1}^{u,+}(p(\mu, h))$  does not intersect  $D^-(\mu, h)$ , then let  $H(\mu, h) = V_{p_1}^{u,+}(p(\mu, h))$ . Otherwise, if  $x$  is the intersection point of  $V_{p_1}^{u,+}(p(\mu, h))$  with  $D^-(\mu, h)$  and  $l$  is the line between  $x$  and  $p(\mu, h)$ , we let  $H(\mu, h)$  be the union of the piece of  $W^{u,+}(p(\mu, h))$  between  $p(\mu, h)$  and  $x$  and the maximal connected piece of  $l$ , containing  $x$ , so that the sum of the length of both pieces together is at most  $p_1$ . We claim that  $H(\mu, h)$  varies continuously with  $(\mu, h)$  for  $(\mu, h) \in \mathfrak{V}$ . Indeed,  $W_{\text{loc}}^{u,+}(p(\mu, h))$  depends continuously on  $(\mu, h)$ . By the flow box theorem, compact parts of  $W_{\text{loc}}^{u,+}(p(\mu, h))$  that lie outside a neighborhood of  $p(\mu, h)$ , vary continuously with  $(\mu, h)$ . The above derived items (a) and (b) imply that parts of  $W_{\text{loc}}^{u,+}(p(\mu, h))$  near  $p(\mu, h)$  also depend continuously on  $(\mu, h)$ . Because  $H(\mu, h)$  is a curve of length at most  $p_1$ , the limit  $\lim_{n \rightarrow \infty} H(\mu_n, h_n)$  is a homoclinic orbit of length at most  $p_1$ .  $\square$

We first prove Theorem 5.2 for generic families. We then use this result plus density of the generic families, to prove Theorem 5.2 for arbitrary families. The following lemma, the continuation result for generic families, can also be obtained as a corollary of the pathfollowing theory developed in [11].

**Lemma 5.5** *Let  $\{X_\lambda\} \in \mathfrak{V}_2$  and let  $(\kappa, \gamma) \in G_1$  be a generically unfolding codimension-one homoclinic orbit of  $\{X_\lambda\}$ . Then  $(\kappa, \gamma)$  is globally I-continuable.*

PROOF. We have seen that near generically unfolding codimension-one and codimension-two homoclinic orbits,  $G_1$  is a one dimensional manifold. The connected component  $\Gamma_1$  of  $G_1$  that contains  $(\kappa, \gamma)$  is therefore homeomorphic either to a circle or to  $(-1, 1)$ . Consider the latter case and let  $g : (-1, 1) \rightarrow G_1$  be a homeomorphism with  $g(0) = (\kappa, \gamma)$ . Suppose that  $C = g([0, 1])$  is bounded and that  $\tau$  is bounded over  $g([0, 1])$ . For a sequence  $s_i \uparrow 1$ , let  $(\mu_i, h_i) = g(s_i)$ . By taking a subsequence we may assume

that  $(\mu_i, h_i)$  converges to  $(\bar{\mu}, \bar{h})$ . By Lemma 5.4, if  $(\bar{\mu}, \bar{h})$  has bounded virtual lengths then  $\bar{h}$  either contains a nonhyperbolic singularity, or consists of more than two orbits, or is the union of a hyperbolic singularity and a homoclinic orbit. In the latter case, since  $\{X_\lambda\}$  is a generic family,  $(\bar{\mu}, \bar{h})$  would be  $I$ -continuable, contradicting the definition of  $G_1$ . The lemma follows.  $\square$

As mentioned before, we will prove Theorem 5.2 by approximating the family  $\{X_\lambda\}$  by generic families for which Lemma 5.5 can be applied. We first introduce some notation. Let  $\{X_\lambda\}$  and  $(\kappa, \gamma)$  be as in Theorem 5.2 and let  $G_1$  be as in (5.3). Write  $\Gamma_1$  for the connected component of  $G_1$  containing  $(\kappa, \gamma)$ . Let  $\mathcal{V} \subset \mathbb{R}^2$  be a small neighborhood of  $\kappa$ . Now  $\{\mu; (\mu, h) \in \Gamma_1\} \cap \mathcal{V}$  is a smooth curve. Let  $M$  be a curve in  $\mathcal{V}$  transverse to  $\{\mu; (\mu, h) \in \Gamma_1\}$ . By Lemma 5.3, we can take a sequence of families  $\{Y_\lambda^i\} \in \mathfrak{Y}_2$  with  $\{Y_\lambda^i\} \rightarrow \{X_\lambda\}$  as  $i \rightarrow \infty$ . Let  $G_1^i$  be defined as  $G_1$ , but then for  $\{Y_\lambda^i\}$ . For  $i$  high, there is a unique point  $(\kappa^i, \gamma^i) \in G_1^i$  so that  $\kappa^i \in M$  and  $(\kappa^i, \gamma^i) \rightarrow (\kappa, \gamma)$  as  $i \rightarrow \infty$ . Furthermore,  $\tau(\kappa^i, \gamma^i) = \{l(\kappa^i, \gamma^i)\}$  for large  $i$ .

**PROOF OF THEOREM 5.2.** Assume  $(\kappa, \gamma)$  is not globally  $I$ -continuable. Then  $\Gamma_1 \setminus \{(\kappa, \gamma)\}$  is not connected. There is a component  $C_1$  of  $\Gamma_1 \setminus \{(\kappa, \gamma)\}$  so that  $C_1$  is bounded and, denoting

$$p_0 = \inf_{(\nu, g) \in C_1} l(\nu, g), \quad (5.4)$$

$$p_1 = \sup_{(\nu, g) \in C_1} \tau(\nu, g), \quad (5.5)$$

we have  $p_0 > 0$  (since otherwise there would exist  $(\mu, h)$  in the closure of  $C_1$  with  $h$  a nonhyperbolic singularity of  $X_\mu$ ) and  $p_1 < \infty$ . Also, there is no homoclinic orbit  $(\mu, h)$  in the closure of  $C_1$  with unbounded virtual lengths.

We claim that  $C_1$  is closed. Indeed, let  $(\mu_i, h_i) \in C_1$  be a sequence converging to a point  $(\mu, h)$ . Then by Lemma 5.4,  $(\mu, h) \in G$ . Since  $(\mu, h)$  has bounded virtual lengths, we have in fact  $(\mu, h) \in C_1$ .

Recall that  $M$  is a small curve transverse to  $\{\mu; (\mu, h) \in G_1\}$  at  $(\kappa, \gamma)$ . Let  $\mathcal{W}$  be a small neighborhood of  $\gamma$  in  $\mathcal{P}$ . We claim that for  $\mathfrak{V}$  small enough, the following properties hold.

- $\partial(M \times \mathcal{W}) \cap \mathcal{V} = \emptyset$ .
- $M \times \mathcal{W}$  divides  $\mathfrak{V}$  in two connected components  $\mathfrak{V}^-$  and  $\mathfrak{V}^+$  with, say,  $C_1 \subset \mathfrak{V}^+$ .

- there exists a neighborhood  $\mathcal{U}_1$  of  $\{X_\lambda\}$  so that for any family  $\{Z_\lambda\} \in \mathcal{U}_1$ , there is no  $(\mu, h) \in \mathfrak{V}^+$  with  $h$  an invariant set containing a nonhyperbolic singularity or containing more than 2 orbits.
- there exists a neighborhood  $\mathcal{U}_2 \subset \mathcal{U}_1$  of  $\{X_\lambda\}$  so that for any family  $\{Z_\lambda\} \in \mathcal{U}_2$ , there is no  $(\mu, h) \in \mathfrak{V}^+$ , so that  $h$  is a homoclinic orbit of  $Z_\mu$  with  $l(\mu, h) \in (0, \frac{9}{10}p_0] \cup [\frac{11}{10}p_1, 3p_1]$ .

The first two items are clear. To establish the third item, suppose it were false. Then there would be a decreasing sequence of neighborhoods  $\mathfrak{V}_i^+$  of  $C_1$ , and families  $\{Z_\lambda^i\}$  with  $\{Z_\lambda^i\} \rightarrow \{X_\lambda\}$ , so that there are  $(\nu_i, h_i) \in \mathfrak{V}_i^+$  with  $h_i$  a closed invariant set of  $Z_{\nu_i}$  containing either a nonhyperbolic singularity or more than two orbits. It is easily seen that an accumulation point  $(\nu, h)$  of the sequence  $(\nu_i, h_i)$  gives a closed invariant set  $h$  of  $X_\nu$ , which also contains either a nonhyperbolic singularity or more than two orbits. Similarly one derives the last item. If it were false, there would be a decreasing sequence of neighborhoods  $\mathfrak{V}_i^+$  of  $C_1$ , and families  $\{Z_\lambda^i\}$  with  $\{Z_\lambda^i\} \rightarrow \{X_\lambda\}$ , so that  $\{Z_\lambda^i\}$  possesses a homoclinic orbit  $(\nu_i, h_i) \in \mathfrak{V}_i^+$  with  $l(\nu_i, h_i) \in (0, \frac{9}{10}p_0] \cup [\frac{11}{10}p_1, 3p_1]$ . By Lemma 5.4, the third item and closedness of  $C_1$ , an accumulation point  $(\nu, h)$  of  $\{(\nu_i, h_i)\}$  would lie on  $C_1$ . Hence,  $h$  would be a homoclinic orbit of  $X_\nu$  with either its length being smaller than  $\frac{9}{10}p_0$  or with a virtual length in  $[\frac{11}{10}p_1, 3p_1]$ . This contradicts the definition of  $p_0$  and  $p_1$ .

Recall that  $\{Y_\lambda^i\}$  is a sequence of families in  $\mathfrak{Y}_2$  converging to  $\{X_\lambda\}$ . For  $i$  high enough, we have

- $l(\kappa^i, \gamma^i) < \frac{11}{10}p_1$  and  $\phi(\kappa^i, \gamma^i) = 1$ ,
- $\{Y_\lambda^i\} \in \mathcal{U}_2$ ,

Let  $C_1^i$  be the connected component of  $G_1^i \setminus \{(\kappa^i, \gamma^i)\}$  so that  $C_1^i$ , restricted to a small neighborhood of  $(\kappa^i, \gamma^i)$ , is contained in  $\mathfrak{V}^+$ . Let  $D_1^i$  be the connected component of  $C_1^i \cap \mathfrak{V}$  that contains  $(\kappa^i, \gamma^i)$ . For all  $(\mu, h) \in D_1^i$  and  $i$  high enough, we have  $l(\mu, h) < 3p_1$ . To see this, assume there would be  $(\mu, h) \in D_1^i$  with  $l(\mu, h) \geq 3p_1$ . Because  $l(\kappa^i, \gamma^i) < \frac{11}{10}p_1$  and, for generic families,  $l$  either changes continuously or jumps with a factor 2, there would be  $(\hat{\mu}, \hat{h}) \in D_1^i$  with  $l(\hat{\mu}, \hat{h}) \in [\frac{11}{10}p_1, \frac{22}{10}p_1]$ . This contradicts  $\{Y_\lambda^i\} \in \mathcal{U}_2$  for  $i$  high enough.

Let  $D_1$  be the collection of accumulation points of  $D_1^i$  as  $i \rightarrow \infty$ . By Lemma 5.4,  $D_1 \subset G_1$ . Because  $D_1^i$  is connected for all  $i$  and the sequence

$(\kappa^i, \gamma^i) \in D_1^i$  converges to  $(\kappa, \gamma) \in D_1$ , we have that  $D_1$  is connected. Because  $C_1$  is closed and connected and  $D_1$  has at least the point  $(\kappa, \gamma)$  in common with  $C_1$ , we have

$$D_1 \subset C_1. \quad (5.6)$$

Note that it follows that  $C_1^i \subset \mathfrak{W}^+$  for  $i$  high enough.

Because  $\{Y_\lambda^i\} \in \mathfrak{Y}_2$ ,  $(\kappa^i, \gamma^i)$  is globally I-continuable. Since  $C_1^i \subset \mathfrak{W}^+$  for large  $i$ ,  $C_1^i$  is bounded for large  $i$ . For the same reason, if  $\Gamma_1^i$  denotes the connected component of  $G_1^i$  containing  $(\kappa^i, \gamma^i)$ ,  $\Gamma_1^i \setminus \{(\kappa^i, \gamma^i)\}$  can not be connected. Since  $\{Y_\lambda^i\} \in \mathcal{U}_1$ , there must be  $(\mu_i, h_i) \in C_1^i$  with  $h_i$  a homoclinic orbit of  $Y_{\mu_i}^i$  of length at least  $3p_1$ . This contradicts  $\{Y_\lambda^i\} \in \mathcal{U}_2$  and proves Theorem 5.2.  $\square$

## 6 Homoclinic-doubling cascades

In this section we prove the main theorem of the paper, stating that cascades of homoclinic-doubling bifurcations exist for an open set of two parameter families of vector fields.

Let  $\Psi_{\varepsilon,p,r}(x, y)$  be the rescaled Poincaré return map as obtained in Section 2, see Proposition 2.5. Other notation, in particular the definition of  $\sigma^p$ , will be as in this proposition. We recall our main result, Theorem 2.4.

**Theorem 6.1** *For  $\varepsilon$  fixed and positive, consider the two parameter family of vector fields  $(p, r) \mapsto X_{\sigma^p(\varepsilon,p,r)}$ . If  $\varepsilon$  is small enough, there is a connected set in the  $(p, r)$  parameter plane consisting of homoclinic bifurcation values of  $\{X_{\sigma^p(\varepsilon,p,r)}\}$ , containing a converging sequence of inclination-flip homoclinic bifurcations at which a  $2^{n+1}$ -homoclinic orbit branches.*

PROOF. Recall that  $\Psi_{0,p,r}(x, y) = (f(x; p, r), 0)$ , where

$$f(x; p, r) = p + \frac{r}{1-\beta} (\beta x - x^\beta). \quad (6.1)$$

Here we have written  $\beta$  for  $\beta(0)$ . The function  $f$  is defined on some interval  $(0, A_x]$ , for parameters  $(p, r) \in \mathbb{I} \times \mathbb{J}$ . We may assume that  $A_x > \frac{1}{\beta}^{1/(1-\beta)}$  and further that  $[1, \frac{1}{\beta}^{1/(1-\beta)}]$  is contained in both  $\mathbb{I}$  and  $\mathbb{J}$ . A computation shows

that  $f^2(0; p, r) = 0$  for parameter values on the curve

$$\mathbf{H}_2 = \left\{ (p, r); p = \left( \frac{r}{1 - \beta(1 - r)} \right)^{1/(1-\beta)} \right\}, \quad (6.2)$$

see Figure 7. Observe that  $\mathbf{H}_2$  is tangent to the diagonal at  $(p, r) = (1, 1)$ . Furthermore, along  $\{(p, r); p = \frac{1}{\beta}^{1/(1-\beta)}\}$ , the map  $f$  satisfies  $f(p; p, r) = p$ .

We will restrict the parameters  $(p, r)$  to a suitably chosen domain in the parameter plane, bounded by a curve  $K$ . The curve  $K$  is as indicated in Figure 7;  $K$  consists of four parts  $K_1, K_2, K_3, K_4$ , where for some constants  $d, P_1, P_2, R_1$ ,

$$\begin{aligned} K_1 &\subset \{(p, r); p - r = d\}, \\ K_2 &\subset \{(p, r); p = P_2\}, \\ K_3 &\subset \{(p, r); r = R_1\}, \\ K_4 &\subset \{(p, r); p = P_1\}. \end{aligned}$$

We take  $d > 0$ ,  $P_1 < 1$  and  $P_2 > \frac{1}{\beta}^{1/(1-\beta)}$ . Take  $R_1 \geq P_2$ . Note that we can choose  $K$  so that  $K \subset \mathbb{I} \times \mathbb{J}$ . Also, by Remark 2.7, we can choose  $K$  so that for  $(p, r)$  inside the region bounded by  $K$  the eigenvalue conditions  $\alpha > 1$  and  $\frac{1}{2} < \beta < 1$  hold.

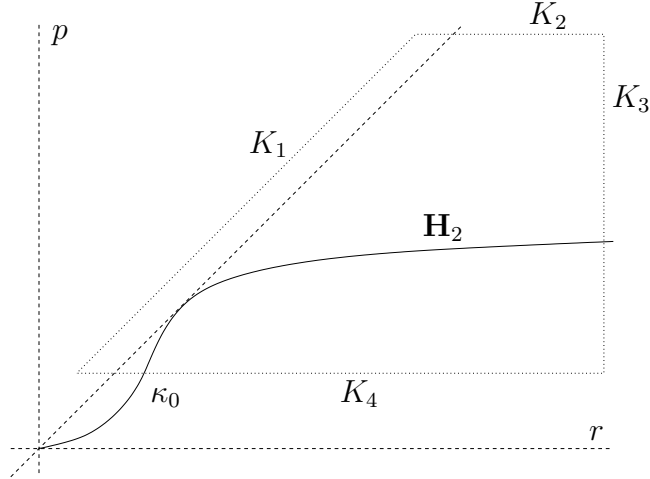

Figure 7: The choice of the curve  $K$ .

We first derive some information on the set of homoclinic bifurcation values of  $\{X_{\sigma^p(\varepsilon,p,r)}\}$  for fixed small positive  $\varepsilon$  on  $K$ . Note that  $\mathbf{H}_2$  intersects  $K_4$  in a unique point  $\kappa_0$ .

**Lemma 6.2** *For  $\varepsilon$  small and positive, there is a unique  $\kappa \in K_4$  near  $\kappa_0$  for which  $X_{\sigma^p(\varepsilon,\kappa)}$  possesses a 2-homoclinic orbit. This homoclinic bifurcation unfolds generically. Further,  $\{X_{\sigma^p(\varepsilon,p,r)}\}$  has no homoclinic orbits for  $(p,r) \in K_1 \cup K_2$ .*

PROOF. Write  $\Psi_{\varepsilon,p,r} = (\Psi_{\varepsilon,p,r}^1, \Psi_{\varepsilon,p,r}^2)$ . Note that  $\Psi_{\varepsilon,p,r}(0,0) = (p,0)$ . Compute  $\frac{\partial}{\partial r} f(p;p,r) = (\beta p - p^\beta)/(1-\beta)$ , which is nonzero. Therefore, for  $\varepsilon$  small and positive,  $\frac{\partial}{\partial r} \Psi_{\varepsilon,p,r}^1(p,0) \neq 0$ . The existence and generic unfolding of the homoclinic bifurcation at  $\kappa$  follows.

For  $\varepsilon = 0$  and  $(p,r) \in K_1$ ,  $f(x;p,r) \geq d$  for all  $x$ . Therefore, if  $\varepsilon$  is sufficiently small,  $\{X_{\sigma^p(\varepsilon,p,r)}\}$  has no homoclinic orbits for  $(p,r) \in K_1$ . For  $\varepsilon = 0$  and  $(p,r) \in K_2$ ,  $f^n(0;p,r) > p$  for all positive integers  $n$ . It follows that if  $\varepsilon$  is sufficiently small,  $\{X_{\sigma^p(\varepsilon,p,r)}\}$  has no homoclinic orbits for  $(p,r) \in K_2$ .  $\square$

We mention that  $\{X_{\sigma^p(\varepsilon,p,r)}\}$  has many homoclinic bifurcation values for  $(p,r) \in K_3$ .

We continue the proof of Theorem 6.1. Let  $\gamma$  denote the closure of the homoclinic orbit of  $X_{\sigma^p(\varepsilon,\kappa)}$ . Theorem 6.1 is proved by applying Theorem 5.2 to  $(\kappa, \gamma)$ . We first show how to compute  $\phi$ , see (5.2) for the definition, for certain homoclinic orbits of  $\{X_{\sigma^p(\varepsilon,p,r)}\}$ . From this, it will follow that  $\phi(\kappa, \gamma) = 1$  for small enough  $\varepsilon$ , so that Theorem 5.2 can be applied to  $(\kappa, \gamma)$ .

By Lemma 4.2, there is a parameter set  $\mathcal{S}$  of the form

$$\mathcal{S} = \{(\varepsilon, p, r); p - r < 0, 0 < \varepsilon < \bar{\varepsilon}(r - p)\}, \quad (6.3)$$

where  $\bar{\varepsilon}$  is a positive function on  $(0, \infty)$  with  $\lim_{s \rightarrow 0} \bar{\varepsilon}(s) = 0$ , so that  $\Psi$  possesses an invariant strong stable foliation for  $(\varepsilon, p, r) \in \mathcal{S}$ . Let  $(\varepsilon, \nu) \in \mathcal{S}$  be so that  $X_{\sigma^p(\varepsilon,\nu)}$  possesses a homoclinic orbit  $h$ . We will indicate how to compute  $\phi(\nu, h)$ . Take continuous coordinates so that the strong stable foliation of  $\Psi$ , for  $(\varepsilon, p, r) \in \mathcal{S}$ , has leaves parallel to the  $z$ -axis. In these coordinates,

$$\Psi_{\varepsilon,p,r}(x, z) = (f_\varepsilon(x; p, r), g(x, z; p, r, \varepsilon)), \quad (6.4)$$

for some functions  $f_\varepsilon, g$ . Recall that a homoclinic orbit of  $X_{\sigma^p(\varepsilon,p,r)}$  corresponds to 0 being a periodic orbit of  $f_\varepsilon(x; p, r)$ . Let  $m$  be the minimal



integer with  $f_\varepsilon^m(0; \nu) = 0$ . Now

$$\phi(\nu, h) = \begin{cases} 1, & \text{if } f_\varepsilon^m(x; \lambda) \text{ is increasing near } 0, \\ 0, & \text{if } f_\varepsilon^m(x; \lambda) \text{ is decreasing near } 0. \end{cases} \quad (6.5)$$

It is clear that for  $\varepsilon$  small enough  $(\varepsilon, \kappa) \in \mathcal{S}$ . We can therefore use (6.5) to get  $\phi(\kappa, \gamma) = 1$ .

As already mentioned, we restrict the parameters  $(p, r)$  to the domain  $\Lambda$  bounded by  $K$ . In the definitions of I-continuable homoclinic orbits, one should replace the condition ‘ $C$  is unbounded’ by ‘ $C$  is unbounded or the closure of  $C$  intersects  $K \times \mathcal{P}$  outside  $(\kappa, \gamma)$ ’.

Let  $C_1$  be the connected component of  $G_1$  containing  $(\kappa, \gamma)$  in its closure. By Lemma 4.3, all homoclinic orbits of  $\{X_{\sigma^p(\varepsilon, \lambda)}\}$  in  $C_1$  are contained in a small tubular neighborhood of the codimension three orbit-flip homoclinic orbit at resonant eigenvalues. From this and the fact that we restrict the parameters  $(p, r)$  to the bounded domain  $\Lambda$ , it follows that  $C_1$  is bounded. Furthermore,  $l|_{C_1}$  is bounded away from 0. In this tubular neighborhood,  $q_\gamma$  is the only singularity. The different possibilities given by Theorem 5.2, can therefore be precised to the following list.

- either the closure of  $C_1$  intersects  $K \times \mathcal{P}$  outside  $(\kappa, \gamma)$ ,
- or  $\tau$  is unbounded over  $C_1$ ,
- or there is a homoclinic orbit in the closure of  $C_1$  with unbounded virtual lengths.

We claim that  $\tau$  is unbounded over  $C_1$ . After establishing this claim, we show that  $\tau$  can only become unbounded through a cascade of homoclinic doubling bifurcations.

We first show that there is no homoclinic orbit in the closure of  $C_1$  with unbounded virtual lengths. By the eigenvalue conditions  $\alpha > 1$  and  $\frac{1}{2} < \beta < 1$ , the only possibly occurring homoclinic orbits of codimension two or more are orbit-flips and inclination-flips (or combined orbit-inclination-flips), see the overview in Subsection 5.1. By Lemma 4.1, orbit-flips do not occur. From inclination-flip homoclinic orbits with the eigenvalue conditions  $\alpha > 1$  and  $\frac{1}{2} < \beta < 1$ , by Theorem A.1 in the appendix, the only possible virtual lengths are one and two times the length of the inclination-flip homoclinic orbit.

To show that  $\tau$  is unbounded over  $C_1$ , let  $\{Y_\lambda^i\} \in \mathfrak{Y}_2$  be a sequence of generic families converging to  $\{X_{\sigma^p(\varepsilon, \lambda)}\}$  as  $i \rightarrow \infty$ . Let  $G^i, G_1^i$  be defined as  $G, G_1$  (see (5.1), (5.3)), but then for  $\{Y_\lambda^i\}$ . For  $i$  high,  $\{Y_\lambda^i\}$  has a unique homoclinic orbit  $(\kappa^i, \gamma^i) \in K \times G_1^i$  near  $(\kappa, \gamma)$ . Let  $C_1^i$  be the connected component of  $G_1^i$  that contains  $(\kappa^i, \gamma^i)$  in its closure. By the same reasoning as above for  $C_1$ , one shows that for large  $i$  there is no homoclinic orbit  $(\mu, h)$  in the closure of  $C_1^i$  with unbounded virtual lengths. By Lemma 6.3,  $\{\mu; (\mu, h) \in C_1^i\}$  is contained in  $\Lambda$ , its closure intersects  $K$  only in  $\kappa^i$ . Therefore, by Lemma 5.5,  $\tau|_{C_1^i}$  is unbounded. From arguments used in the proof of Theorem 5.2 it is now clear that  $\tau$  restricted to the closure of  $C_1$  is unbounded.

It remains to show that  $\tau|_{C_1}$  being unbounded implies the existence of a cascade of homoclinic-doubling bifurcations in  $C_1$ . Recall that all homoclinic orbits of  $\{X_{\sigma^p(\varepsilon, \lambda)}\}$  in  $C_1$  are contained in a small tubular neighborhood of the codimension three orbit-flip homoclinic orbit. There are therefore constants  $k_1, k_2$  close to 1 and  $l_0 > 0$  so that

$$l(\mu, h) \in [Nk_1l_0, Nk_2l_0], \quad (6.6)$$

if  $(\mu, h) \in C_1$  is an  $N$ -homoclinic orbit. In fact,  $l_0$  is the length of the orbit-flip homoclinic orbit at resonant eigenvalues. It follows that  $\tau|_{C_1}$  can only become unbounded if  $C_1$  contains  $N$ -homoclinic orbits for arbitrarily large  $N$ . We have seen above that for each  $(\mu, h) \in C_1$ , either  $\tau(\mu, h) = \{l(\mu, h)\}$  or  $\tau(\mu, h) = \{l(\mu, h), 2l(\mu, h)\}$ . Therefore  $C_1$  can only contain  $N$ -homoclinic orbits for arbitrarily large  $N$  if there is a cascade of inclination-flip homoclinic orbits on  $C_1$ .  $\square$

**Lemma 6.3** *Let  $\{Y_\lambda^i\}$ ,  $\kappa^i$ ,  $C_1^i$  and  $K$  be as in the proof of Theorem 6.1. Then the closure of  $\{\mu; (\mu, h) \in C_1^i\}$  intersects  $K$  only in  $\kappa^i$ .*

PROOF. Denote

$$s_n = \{\mu; (\mu, h) \in G^i, h \text{ is an } n\text{-homoclinic orbit of } Y_\mu^i\}. \quad (6.7)$$

Because  $\{Y_\lambda^i\}$  is a generic family,  $s_n$  consists of a finite set of piecewise smooth curves. Write  $\eta_n = \partial s_n$ ,  $\eta_n^1 = \eta_n \cap \{\mu; (\mu, h) \in G_1^i\}$  and  $\eta_n^0 = \eta_n \setminus \eta_n^1$ .

Homoclinic bifurcation values of  $Y_\lambda^i$  on  $K$  are contained in  $K_3 \cup K_4$ . In fact,  $K_4$  contains just one homoclinic bifurcation value,  $\kappa^i \in \eta_2^1$ , with  $\kappa^i \rightarrow \kappa$

as  $i \rightarrow \infty$ . All other homoclinic bifurcation values on  $K$  are contained in  $K_3$ . Let  $\sigma : K \mapsto [0, 1)$  be a coordinate traversing  $K$  counterclockwise, with  $\sigma^{-1}(0) \in K_1 \cup K_2$ . We first prove the lemma under the assumption that, as  $\sigma$  increases, periodic orbits are created and not annihilated in homoclinic bifurcations.

Following Section 3.2, which summarizes results from Section 4.3 in [18], homoclinic bifurcation values on  $K$  satisfy the following properties. For  $Q$  a positive integer, we will describe  $K \cap (\eta_2 \cup \eta_4 \cup \dots \cup \eta_{2Q})$ . Note that  $(\eta_2^1 \cup \eta_4^1 \cup \dots \cup \eta_{2Q}^1) \cap K$  is a finite set, say

$$(\eta_2^1 \cup \eta_4^1 \cup \dots \cup \eta_{2Q}^1) \cap K = \{\nu_1, \dots, \nu_N\}, \quad (6.8)$$

with  $\nu_1 = \kappa^i$  and  $\sigma(\nu_1) < \dots < \sigma(\nu_N)$ . For  $j$  with  $1 \leq j \leq N$ , let  $I(j)$  be defined by

$$\nu_j \in \eta_{2^{I(j)}}^1. \quad (6.9)$$

By Section 3.2, for  $1 \leq j < N$ , the finite bifurcation set on the piece of  $K$  between  $\nu_j$  and  $\nu_{j+1}$ , is as follows:

$$(\eta_2^0 \cup \eta_4^0 \cup \dots \cup \eta_{2Q}^0) \cap \{\lambda \in K; \sigma(\lambda) \in (\sigma(\nu_j), \sigma(\nu_{j+1}))\} = \{\zeta_{j,1}, \dots, \zeta_{j,Q+1-I(j)}\}, \quad (6.10)$$

where  $\sigma(\zeta_{j,1}) < \dots < \sigma(\zeta_{j,Q+1-I(j)})$  and

$$\zeta_{j,h} \in \eta_{2^{I(j)+h-1}}^0, \quad (6.11)$$

$1 \leq h \leq Q + 1 - I(j)$ . The set  $\eta_2^1 \cap K$  consists of a unique bifurcation value;

$$\eta_2^1 \cap K = \nu_1. \quad (6.12)$$

If  $g$  is a curve in  $s_{2^j}$ , where  $s_{2^j}$  is defined in (6.7), then  $g$  is homeomorphic either to a circle or to an open interval. The following information on the number on points of  $g$  in  $\eta_{2^{j+1}}^1$  respectively in  $\eta_{2^{j+1}}^0$  will be used frequently in the sequel. The three items are easy consequences of the fact that  $\{Y_\lambda^i\}$  is a generic family and of the possible local bifurcation diagrams.

- Suppose  $g$  is homeomorphic to a circle. Then  $\text{card } g \cap \eta_{2^{j+1}}^1$  is even and  $g \cap \eta_{2^{j+1}}^0 = \emptyset$ .

- With  $\partial g = \{g_1, g_2\}$ , suppose both  $g_1, g_2 \subset \eta_{2^j}^1$  or both  $g_1, g_2 \subset \eta_{2^j}^0$ . Then  $\text{card } g \cap \eta_{2^{j+1}}^1$  is even and  $g \cap \eta_{2^{j+1}}^0 = \emptyset$ .
- With  $\partial g = \{g_1, g_2\}$ , suppose  $g_1 \subset \eta_{2^j}^1$  and  $g_2 \subset \eta_{2^j}^0$  (or vice versa). Then  $\text{card } g \cap \eta_{2^{j+1}}^1$  is odd and  $g \cap \eta_{2^{j+1}}^0 = \emptyset$ .

Write

$$\Sigma_1^i = \{\mu; (\mu, h) \in C_1^i\}. \quad (6.13)$$

Suppose there is an integer  $Q$  such that  $\Sigma_1^i \cap (s_2 \cup \dots \cup s_{2^Q})$  intersects  $K$  in two points  $\nu_1$  and  $\nu_l$ . We will derive a contradiction from this assumption, thus proving the lemma. Figure 8 illustrates the reasoning, consisting of a counting argument, with an example.

Let  $H$  be the connected component of  $\Lambda \setminus \Sigma_1^i$  that contains  $\{\lambda \in K; \sigma(\nu_1) \leq \sigma(\lambda) \leq \sigma(\nu_l)\}$  in its boundary. We restrict the parameter  $\lambda$  to the open domain  $H$ , the definitions of  $s_n$  and  $\eta_n$  are consequently altered;

$$s_n = \{\mu \in H; (\mu, h) \in G^i, h \text{ is an } n\text{-homoclinic orbit of } Y_\mu^i\} \quad (6.14)$$

Write  $\eta_n = \partial s_n$ ,  $\eta_n^1 = \eta_n \cap \{\mu; (\mu, h) \in G_1^i\}$  and  $\eta_n^0 = \eta_n \setminus \eta_n^1$ . Let  $S_n$  be the union of the curves in  $s_n$  that have an endpoint in  $\eta_n^0$ .

Observe that for all positive integers  $j$ ,

$$\eta_{2^j}^0 \subset \partial H. \quad (6.15)$$

Since  $\Sigma_1^i \subset \{\mu; (\mu, h) \in G_1^i\}$ , curves in  $s_{2^j}^1$  can not end at  $\Sigma_1^i$ , so that

$$\eta_{2^j}^1 \cap \Sigma_1^i = \emptyset, \quad (6.16)$$

for all positive integers  $j$ . We now first list some properties concerning the number of points in  $\eta_{2^j}^0$  and  $\eta_{2^j}^1$  for positive integers  $j$ . For a finite set  $S$ , write  $|S|$  for the cardinality of  $S$ . From the description of the bifurcation set on curves in  $s_n$ , we have that for all positive integers  $j$ ,

$$|\eta_{2^{j+1}}^1 \cap S_{2^j}| = |\eta_{2^j}^0| \pmod{2}, \quad (6.17)$$

$$|\eta_{2^{j+1}}^1 \cap (s_{2^j} \setminus S_{2^j})| = 0 \pmod{2}, \quad (6.18)$$

Since the total number of points in  $\eta_{2^j}$  must be even, for all positive integers  $j$ ,

$$|\eta_{2^j}^0| = |\eta_{2^j}^1| \pmod{2}. \quad (6.19)$$

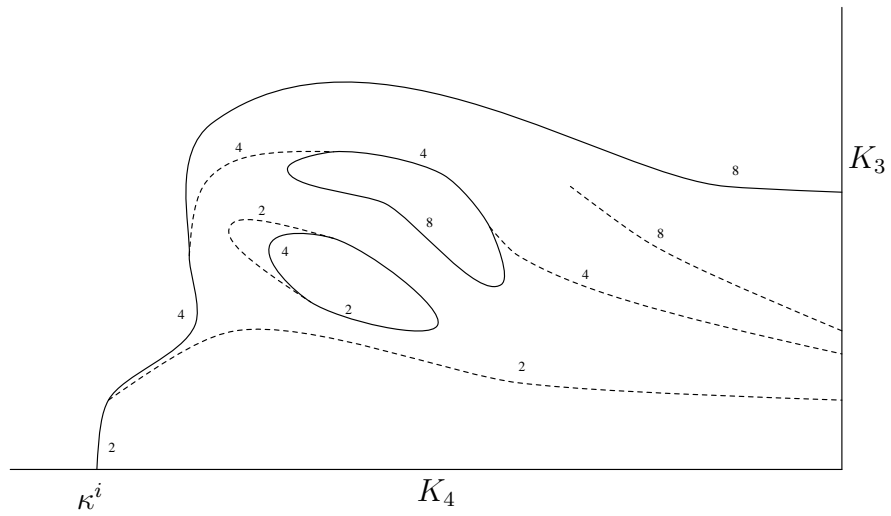

Figure 8: This example illustrates how a contradiction is derived from the assumption that  $\Sigma_1^i$  intersects  $K$  in two points. Curves of homoclinic orbits in the parameter plane are drawn, solid curves correspond to homoclinic orbits on which  $\phi = 1$  and dotted curves correspond to homoclinic orbits on which  $\phi = 0$ . The order of the homoclinic orbits is indicated. In the region  $H$  enclosed by  $\Sigma_1^i$  and part of  $K$ , the number of curves in  $s_8$  does not match the number of endpoints in  $\eta_8$ .

Let  $q$  be a positive integer. From the description of the bifurcation set on  $K$  it follows that

$$|\eta_{2^{q+1}}^0 \cap K \cap \partial H| - |\eta_{2^{q+1}}^1 \cap K \cap \partial H| = |\eta_{2^q}^0 \cap K \cap \partial H|. \quad (6.20)$$

Compute (on top of each equality sign we indicate the equations used, these equations are used either with  $j = q$  or with  $j = q + 1$ ):

$$\begin{aligned} 0 &\stackrel{(6.19)}{=} |\eta_{2^{q+1}}^1| - |\eta_{2^{q+1}}^0| \pmod{2} \\ &\stackrel{(6.15),(6.16)}{=} |\eta_{2^{q+1}}^1 \cap S_{2^q}| + |\eta_{2^{q+1}}^1 \cap (s_{2^q} \setminus S_{2^q})| + |\eta_{2^{q+1}}^1 \cap K \cap \partial H| \\ &\quad - |\eta_{2^{q+1}}^0 \cap K \cap \partial H| - |\eta_{2^{q+1}}^0 \cap \Sigma_1^i| \pmod{2} \\ &\stackrel{(6.18)}{=} |\eta_{2^{q+1}}^1 \cap S_{2^q}| + |\eta_{2^{q+1}}^1 \cap K \cap \partial H| \\ &\quad - |\eta_{2^{q+1}}^0 \cap K \cap \partial H| - |\eta_{2^{q+1}}^0 \cap \Sigma_1^i| \pmod{2} \\ &\stackrel{(6.17),(6.20)}{=} |\eta_{2^q}^0| - |\eta_{2^q}^0 \cap K \cap \partial H| - |\eta_{2^{q+1}}^0 \cap \Sigma_1^i| \pmod{2} \\ &\stackrel{(6.15)}{=} |\eta_{2^q}^0 \cap \Sigma_1^i| - |\eta_{2^{q+1}}^0 \cap \Sigma_1^i| \pmod{2}. \end{aligned}$$

It follows that

$$|\eta_{2^q}^0 \cap \Sigma_1^i| = |\eta_{2^{q+1}}^0 \cap \Sigma_1^i| \pmod{2}. \quad (6.21)$$

Let  $N$  be big enough so that  $\Sigma_1^i \cap s_{2^N} = \emptyset$ . So  $|\eta_{2^N}^0 \cap \Sigma_1^i| = 0$ . Inductively applying (6.21), starting at  $q + 1 = N$ , we get  $|\eta_2^0 \cap \Sigma_1^i| = 0 \pmod{2}$ . On the other hand, using (6.12), we get

$$|\eta_2^0 \cap \Sigma_1^i| = 1 \pmod{2}. \quad (6.22)$$

This contradiction proves the lemma in the special case where periodic orbits are only created in homoclinic bifurcations when traversing  $K$  counterclockwise.

The general case, when periodic orbits may also be annihilated in homoclinic bifurcations when traversing  $K$  counterclockwise, is reduced to the special case by a homotopy argument. Let  $f^i(x; p, r)$  be the Poincaré return map of  $\{Y_\lambda^i\}$ . Let  $t \mapsto H(x; t, p)$ ,  $0 \leq t \leq 1$ , be a homotopy with  $H(x; 0, p) = f^i(x; p, R_1)$ ,  $P_1 \leq p \leq P_2$  and  $H(x; 1, p) = g(x; p)$  where  $g$  is such that periodic orbits are only created in homoclinic bifurcations when increasing  $p$  from  $P_1$  to  $P_2$ . Replace  $f^i(x; p, r)$  by a map  $\tilde{f}^i(x; p, r)$  with

$\tilde{f}^i(x; p, r) = f^i(x; p, r)$  if  $(p, r) \in \Lambda$  and  $\tilde{f}^i(x; p, R_1 + t) = H(x; t, p)$  for  $P_1 \leq p \leq P_2$ ,  $0 \leq t \leq 1$ . By a small perturbation of  $H$  we may assume that homoclinic bifurcations of  $n$ -homoclinic orbits,  $0 \leq n \leq 2^{p+1}$ , occur along smooth curves. Together with the remark that (6.12) still holds in the general case, this reduces to the special case treated above and proves the lemma.  $\square$

## A Inclination-flip

This appendix provides an exposition of the derivation of the bifurcation diagram of a generically unfolding inclination-flip homoclinic bifurcation, with eigenvalues so that it undergoes a homoclinic-doubling. We treat only three dimensional vector fields.

Consider a smooth two-parameter family of vector fields  $\{Y_\gamma\}$ ,  $\gamma \in \mathbb{R}^2$ , on  $\mathbb{R}^3$ , satisfying the following conditions (where notation for invariant manifolds is analogous to the notation used in Section 2):

**(BH: Basic hypothesis)** The vector field  $X_\gamma$  has a hyperbolic singularity  $q_\gamma$  at which the linearization  $DX_\gamma(q_\gamma)$  possesses two negative eigenvalues  $-\alpha(\gamma) < -\beta(\gamma)$  and one positive eigenvalue 1.

**(IF: Inclination-flip)** The vector field  $X_0$  possesses, at the parameter  $\gamma = 0$ , an inclination-flip homoclinic orbit  $\Gamma$ . The homoclinic orbit  $\Gamma$  is not contained in the strong stable manifold  $W_{Y_0}^{ss}(q_0)$ .

**(EC: Eigenvalue conditions)** The eigenvalues of the linearization  $DX_0(q_0)$  satisfy

$$\alpha(0) > 1 \text{ and } \frac{1}{2} < \beta(0) < 1.$$

**(GU: Generic unfolding)** Denote by  $F_\gamma^{s,u}$  the bundle  $\{T_x W_{X_\gamma}^{s,u}(q_\gamma); x \in W_{X_\gamma}^u(q_\gamma)\}$ . The condition is then that  $\bigcup_\gamma (TW_{X_\gamma}^{ss,s}(q_\gamma), \gamma)$  and  $\bigcup_\gamma (F_\gamma^{s,u}, \gamma)$  intersect each other transversally along  $T_\Gamma W_{X_0}^{ss,s}(q_0) \times \{0\}$  in  $T\mathbb{R}^3 \times \mathbb{R}^2$ .

**Theorem A.1** *Let  $\{Y_\gamma\}$  be a two-parameter family of vector fields on  $\mathbb{R}^3$  as above. After a reparametrization of the parameter plane, the bifurcation diagram of  $\{Y_\gamma\}$  for small values of  $\gamma$ , is as depicted below. From the curve*

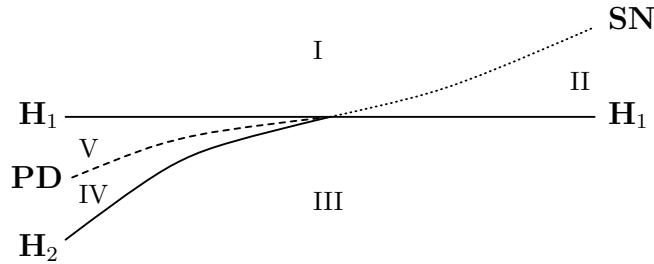

$\mathbf{H}_1$  of primary homoclinic orbits, a curve  $\mathbf{H}_2$  of doubled homoclinic orbits branches. Furthermore, a curve  $\mathbf{SN}$  of periodic saddle-node bifurcations and a curve  $\mathbf{PD}$  of period-doubling bifurcations branch.

The following list describes all periodic orbits of  $\{Y_\gamma\}$  in a tubular neighborhood of  $\bar{\Gamma}$ , for parameters from the different regions  $I, \dots, V$ . In region  $I$ ,  $\{Y_\gamma\}$  has no periodic orbits. In region  $II$ ,  $\{Y_\gamma\}$  has an attracting 1-periodic orbit and a saddle 1-periodic orbit. In region  $III$ ,  $\{Y_\gamma\}$  has an attracting 1-periodic orbit. In region  $IV$ ,  $\{Y_\gamma\}$  has an attracting 1-periodic orbit and a saddle 2-periodic orbit. In region  $V$ ,  $\{Y_\gamma\}$  has a saddle 1-periodic orbit and an attracting 2-periodic orbit.

This bifurcation was studied in [21] and in [22]. The bifurcation curves were computed in [21]. However, information on the number of  $n$ -periodic orbits for  $n > 1$  and  $n$ -homoclinic orbits for  $n > 2$ , was not obtained. Most ingredients for the proof of Theorem A.1 are available in the literature. For instance, it was established in [22], that in a subregion of the parameter plane, a Poincaré return map possesses a strong stable foliation on a part of its domain. This foliation enables a reduction to a one dimensional map and thus excludes the existence of  $n$ -homoclinic orbits and  $n$ -periodic orbits with  $n > 2$ , on the domain of the strong stable foliation and for parameter values from the subregion where the foliation exists. Combining such an argument with a direct computation for the remaining parameter values and remaining points from the domain, proves that for all parameter values near the inclination-flip bifurcation point, no  $n$ -homoclinic orbits or  $n$ -periodic orbits exist for  $n > 2$ . It will be seen that the parameter region where a strong stable foliation exists, includes all bifurcation curves.

By collecting the main arguments from [21], [22] and adding the required additional computations, we provide a proof of Theorem A.1. We will subdivide the proof in different sections, starting with the derivation of bifurcation equations for periodic and homoclinic orbits.



## A.1 Bifurcation equations

We may assume that the origin  $O$  is the singularity of  $\{Y_\gamma\}$  for all small values of  $\gamma$ . Take coordinates  $(x_{ss}, x_s, x_u)$  near  $O$ , so that

$$DY_\gamma(O) = \alpha x_{ss} \frac{\partial}{\partial x_{ss}} + \beta x_s \frac{\partial}{\partial x_s} + x_u \frac{\partial}{\partial x_u}.$$

Take the local coordinates such that the local stable and unstable manifold of  $O$  are linear:

$$W_{\text{loc}}^{ss,s}(O) \subset \{x_u = 0\}, \quad (\text{A.1})$$

$$W_{\text{loc}}^u(O) \subset \{x_{ss} = x_s = 0\}. \quad (\text{A.2})$$

For small positive numbers  $\delta_0 < \delta$  take a cross section

$$\Sigma = \{x_s = \delta, |x_u|, |x_{ss}| \leq \delta_0\},$$

transversally intersecting the homoclinic orbit. By applying a linear rescaling, we may assume that  $\delta = 1$ . By [22], the Poincaré return map  $\Pi$  on  $\Sigma$  has the following expression:

$$\Pi(x_{ss}, x_u; \gamma) = \begin{pmatrix} p + rh(x_{ss}; \gamma)x_u^\beta + k_1(x_{ss}, x_u; \gamma)x_u^\eta \\ \varepsilon + \mu h(x_{ss}; \gamma)x_u^\beta + k_2(x_{ss}, x_u; \gamma)x_u^\eta \end{pmatrix}, \quad (\text{A.3})$$

where  $\eta > 1$ ,  $p, \mu, \varepsilon, r, \beta$  depend smoothly on  $\gamma$ ,  $h(x_{ss}; \gamma)$  is a smooth positive function with  $h(0, 0) = 1$ , and  $k_i(x_u, x_{ss}; \gamma)$ ,  $i = 1, 2$ , are smooth functions defined on  $x_u > 0$  with, for  $k \geq 0, l \geq 0$ ,

$$\lim_{x_u \downarrow 0} \frac{\partial^{k+l}}{\partial^k(x_{ss}, \gamma) \partial^l x_u} k_i(x_{ss}, x_u; \gamma) x_u^l$$

existing and bounded. Compare also Appendix B, in which Proposition 2.9 and the resulting expressions (2.11), (2.12) are proved. The Poincaré return map  $\Pi$  is restricted to  $(x_{ss}, x_u) \in [-\delta_0, \delta_0] \times (0, \delta_0]$ , for  $\delta_0$  some small positive number.

Note that  $\mu$  and  $\varepsilon$  vanish at  $\gamma = 0$  since this expresses the fact that  $Y_0$  possesses an inclination-flip homoclinic orbit. The generic unfolding condition (GU) implies that the derivative  $D(\mu, \varepsilon)$  has full rank at  $\gamma = 0$ . After a reparametrization we may therefore take  $\gamma = (\mu, \varepsilon)$ . The primary homoclinic orbit persists along the line  $\{\varepsilon = 0\}$ .

Let  $(x_{ss,j+1}, x_{u,j+1}) = \Pi(x_{ss,j}, x_{u,j})$  be an orbit of  $\Psi$ . Suppose we are looking for  $N$ -periodic orbits or  $N$ -homoclinic orbits for some fixed  $N$ . For an  $N$ -periodic orbit,  $x_{ss,N} = x_{ss,0}$ ,  $x_{u,N} = x_{u,0}$  and furthermore  $x_{u,j} > 0$  for all  $j$ . For an  $N$ -homoclinic orbit,  $x_{ss,N} = x_{ss,0}$ ,  $x_{u,N} = x_{u,0} = 0$  and  $x_{u,j} > 0$  for  $0 < j < N$ . Let

$$\Psi_j = \begin{pmatrix} x_{ss,j+1} \\ x_{u,j+1} \end{pmatrix} - \Pi(x_{ss,j}, x_{u,j}). \quad (\text{A.4})$$

We take the indices  $j$  in  $\Psi_j$ ,  $x_{ss,j}$ ,  $x_{u,j}$  modulo  $N$ . Write  $\Psi = (\Psi_0, \dots, \Psi_{N-1})$ . Write  $\mathbf{x}_{ss} = (x_{ss,0}, \dots, x_{ss,N-1})$  and  $\mathbf{x}_u = (x_{u,0}, \dots, x_{u,N-1})$ . Note that  $\Psi$  vanishes on  $N$ -periodic and  $N$ -homoclinic orbits.

Let  $\mathbf{P}$  be the orthogonal projection onto the image  $\text{Im } D_{\mathbf{x}_{ss}} \Psi|_{\mathbf{x}_u=0}$ . It is easily computed that

$$D_{\mathbf{x}_{ss}} \Psi|_{\mathbf{x}_u=0} \cdot (\hat{x}_{ss,0}, \hat{x}_{u,0}, \dots, \hat{x}_{ss,N-1}, \hat{x}_{u,N-1}) = (\hat{x}_{ss,0}, 0, \dots, \hat{x}_{ss,N-1}, 0). \quad (\text{A.5})$$

Performing a Lyapounov-Schmidt reduction the equation  $\Psi = \mathbf{0}$  will be splitted in the equations  $(\mathbf{I} - \mathbf{P})\Psi = \mathbf{0}$  and  $\mathbf{P}\Psi = \mathbf{0}$ . This strategy was also followed in [6], [21]. In this set-up, using (A.5) the following lemma is not hard to derive.

**Lemma A.2** *The equation  $(\mathbf{I} - \mathbf{P})\Psi = \mathbf{0}$  can be solved for  $\mathbf{x}_{ss}$  as function of  $\mathbf{x}_u$ . The following estimate holds for  $k \geq 0$ :*

$$\left\| \frac{\partial^{k+l}}{\partial^k \gamma \partial^l \mathbf{x}_u} (x_{ss,j}(\mathbf{x}_u) - x_{ss,j}(\mathbf{0})) \right\| \leq C_{k+l} \|\mathbf{x}_u\|^{\beta-l}$$

for some  $C_{k+l} > 0$ . Putting  $\mathbf{x}_{ss}(\mathbf{x}_u)$  into the equation  $\mathbf{P}\Psi = \mathbf{0}$ , we obtain the reduced bifurcation equations

$$x_{u,j+1} = \varepsilon + \mu x_{u,j}^\beta + U_j(\mathbf{x}_u; \gamma), \quad (\text{A.6})$$

for  $0 \leq j < N$ . The function  $U_j$  is smooth for  $x_{u,j} > 0$ ,  $0 \leq j < N$ , and there exist  $\eta > 1$ ,  $C_{k+l} > 0$  so that

$$\left\| \frac{\partial^{k+l}}{\partial^k \gamma \partial^l \mathbf{x}_u} U_j(\mathbf{x}_u; \gamma) \right\| \leq C_{k+l} \|\mathbf{x}_u\|^{\eta-l}.$$

□

## A.2 Computation of the bifurcation curves

Now we use the reduced bifurcation equations from Lemma A.2 to solve for bifurcations of  $n$ -periodic and  $n$ -homoclinic orbits,  $n = 1, 2$ .

### 1-periodic orbits.

For a 1-periodic orbit, (A.6) becomes an equation of the form  $x_u = \varepsilon + \mu x_u^\beta + U(x_u; \gamma)$ . To compute the parameter values where saddle-node bifurcations of 1-periodic orbits occur, one has to solve the system

$$\begin{aligned} x_u &= \varepsilon + \mu x_u^\beta + U(x_u; \gamma), \\ 1 &= \beta \mu x_u^{\beta-1} + U'(x_u; \gamma). \end{aligned}$$

Here  $U(x_u; \gamma) = \mathcal{O}(x_u^\eta)$  and  $U'(x_u; \gamma) = \mathcal{O}(x_u^{\eta-1})$ . Solving these equations, one obtains  $\mu > 0$  and

$$\varepsilon = \left( \beta^{\frac{1}{1-\beta}} - \beta^{\frac{\beta}{1-\beta}} \right) \mu^{\frac{1}{1-\beta}} + o(\mu^{\frac{1}{1-\beta}}).$$

### 2-homoclinic orbits.

For a two-homoclinic orbit, (A.6) becomes

$$\begin{aligned} x_{u,1} &= \varepsilon + \mu x_{u,0}^\beta + U_1(x_{u,0}, x_{u,1}; \gamma), \\ x_{u,0} &= \varepsilon + \mu x_{u,1}^\beta + U_0(x_{u,0}, x_{u,1}; \gamma), \end{aligned}$$

with  $x_{u,0} = 0$  and  $x_{u,1} > 0$ . Thus we get

$$\begin{aligned} x_{u,1} &= \varepsilon, \\ 0 &= \varepsilon + \mu x_{u,1}^\beta + U_0(0, x_{u,1}; \gamma). \end{aligned}$$

Solving this one obtains  $\mu < 0$  and

$$\varepsilon = (-\mu)^{\frac{1}{1-\beta}} + o((-\mu)^{\frac{1}{1-\beta}}).$$

### 2-periodic orbits.

For a 2-periodic orbit, (A.6) becomes

$$\begin{aligned} x_{u,1} &= \varepsilon + \mu x_{u,0}^\beta + U_1(x_{u,0}, x_{u,1}; \gamma), \\ x_{u,0} &= \varepsilon + \mu x_{u,1}^\beta + U_0(x_{u,0}, x_{u,1}; \gamma), \end{aligned}$$

with  $x_{u,0}$  and  $x_{u,1}$  positive. We may assume that  $x_{u,0} < x_{u,1}$  and write  $x_{u,1} = x_u, x_{u,0} = ax_u$  for some  $0 < a < 1$ . The equations to solve are

$$\begin{aligned} x_u &= \varepsilon + \mu a^\beta x_u^\beta + U_1(ax_u, x_u; \gamma), \\ ax_u &= \varepsilon + \mu x_u^\beta + U_0(ax_u, x_u; \gamma). \end{aligned}$$

By symmetry,  $U_0(ax_u, x_u; \gamma) = U_1(x_u, ax_u; \gamma)$ . Subtracting the both equations and dividing by  $(1-a)x_u^\beta$  yields

$$x_u^{1-\beta} = \mu \frac{a^\beta - 1}{1-a} + \frac{U_1(ax_u, x_u; \gamma) - U_1(x_u, ax_u; \gamma)}{(1-a)x_u^\beta}. \quad (\text{A.7})$$

Here  $U_1(ax_u, x_u; \gamma) - U_1(x_u, ax_u; \gamma) = \mathcal{O}((1-a)x_u^\eta)$  as  $a \rightarrow 1$ . It follows that (A.7) has a well defined limit as  $a \rightarrow 1$ ,

$$x_u^{1-\beta} = -\mu\beta + \bar{U}(x_u; \gamma).$$

Here  $\bar{U}(x_u; \gamma) = \mathcal{O}(x_u^{\eta-\beta})$ . Note that  $\eta - \beta > 0$  since  $\eta > 1$ . We thus obtain period-doubling bifurcations if  $\mu < 0$  and

$$\varepsilon = \left( \beta^{\frac{1}{1-\beta}} + \beta^{\frac{\beta}{1-\beta}} \right) (-\mu)^{\frac{1}{1-\beta}} + o((-\mu)^{\frac{1}{1-\beta}}).$$

A straightforward computation shows that the period-doubling bifurcation is supercritical [15].

### A.3 Invariant foliations

It remains to show that no  $n$ -periodic orbits and  $n$ -homoclinic orbits exist, for  $n > 2$ . For this we will construct invariant strong stable foliations for  $\Pi$ . Also the statements on stability of periodic orbits are a direct consequence of preceding computations and the existence of a strong stable foliation.

We will cover a neighborhood  $\mathcal{W}$  of  $\gamma = 0$  in the parameter plane by two regions  $\mathcal{W}_1$  and  $\mathcal{W}_2$ . For a positive constant  $E$ , let

$$\begin{aligned} \mathcal{W}_1 &= \{(\varepsilon, \mu) \in \mathcal{W}; |\varepsilon| \leq E|\mu|^{\frac{1}{1-\beta}}\}, \\ \mathcal{W}_2 &= \{(\varepsilon, \mu) \in \mathcal{W}; |\varepsilon| \geq E|\mu|^{\frac{1}{1-\beta}}\}. \end{aligned}$$

Below, we will need to choose  $E$  sufficiently large. For parameters from  $\mathcal{W}_1$ , a strong stable foliation for  $\Pi$  will be constructed. Dynamics of  $\Pi$  for parameters from  $\mathcal{W}_2$  is studied separately.

## Parameters from $\mathcal{W}_2$ .

We parametrize  $\mathcal{W}_2$  by parameters  $(\varepsilon, k)$ , where  $k$  is given by  $\mu = k|\varepsilon|^{1-\beta}$ ;  $k$  is contained in  $[-(\frac{1}{E})^{1-\beta}, (\frac{1}{E})^{1-\beta}]$ . Consider rescaled coordinates  $(\hat{x}_{ss}, \hat{x}_u)$  given by

$$\begin{pmatrix} x_{ss} \\ x_u \end{pmatrix} = \begin{pmatrix} |\varepsilon|^{1-\beta} & 0 \\ 0 & |\varepsilon| \end{pmatrix} \begin{pmatrix} \hat{x}_{ss} \\ \hat{x}_u \end{pmatrix} + \begin{pmatrix} p \\ 0 \end{pmatrix}.$$

Computing the Poincaré return map  $(\hat{x}_{ss}, \hat{x}_u) \mapsto \hat{\Pi}(\hat{x}_{ss}, \hat{x}_u; \varepsilon, k)$  in rescaled coordinates and with parameters  $(\varepsilon, k)$ , one gets

$$\hat{\Pi}(\hat{x}_{ss}, \hat{x}_u; \varepsilon, k) = \begin{pmatrix} \hat{x}_u^\beta r h |\varepsilon|^{2\beta-1} + \hat{x}_u^\eta k_1 |\varepsilon|^{\eta+\beta-1} \\ \text{sign}(\varepsilon) + k \hat{x}_u^\beta h + \hat{x}_u^\eta k_2 |\varepsilon|^{\eta-1} \end{pmatrix}.$$

Here  $h$  is evaluated at  $(x_{ss}; \gamma) = (|\varepsilon|^{1-\beta} \hat{x}_{ss} + p; k|\varepsilon|^{1-\beta}, \varepsilon)$  and  $k_i$ ,  $i = 1, 2$ , is evaluated at  $(x_{ss}, x_u; \gamma) = (|\varepsilon|^{1-\beta} \hat{x}_{ss} + p, |\varepsilon| \hat{x}_u; k|\varepsilon|^{1-\beta}, \varepsilon)$ . As  $\varepsilon \rightarrow 0$ ,  $\hat{\Pi}(\hat{x}_{ss}, \hat{x}_u; \varepsilon, k) \rightarrow \hat{\Pi}_0(\hat{x}_{ss}, \hat{x}_u; \varepsilon, k)$ , given by

$$\hat{\Pi}_0(\hat{x}_{ss}, \hat{x}_u; \varepsilon, k) = \begin{pmatrix} 0 \\ \text{sign}(\varepsilon) + k \hat{x}_u^\beta \end{pmatrix}.$$

This convergence is uniform on sets of the form  $[-I, I] \times (0, I]$ , where  $I$  is a positive number. It is clear that  $\hat{\Pi}_0$  has a stable fixed point if  $\varepsilon > 0$ , attracting all points in its domain. If  $\varepsilon < 0$ , all points of  $\hat{\Pi}_0$  are eventually mapped outside the domain of  $\hat{\Pi}_0$ . If we consider only small values of  $k$ , i.e. if  $E$  is chosen sufficiently large, then for  $\varepsilon$  small and positive,  $\hat{\Pi}$  has a stable fixed point in  $[-I, I] \times (0, I]$ , which attracts all points in  $[-I, I] \times (0, I]$ . And if  $\varepsilon$  is small and negative, all points in  $[-I, I] \times (0, I]$  are mapped outside the domain of  $\hat{\Pi}$ .

The range  $[-\delta_0, \delta_0] \times (0, \delta_0]$  of  $(x_{ss}, x_u)$ -values for which we have to study  $\Pi$ , corresponds to  $[-\frac{1}{|\varepsilon|}\delta_0, \frac{1}{|\varepsilon|}\delta_0] \times (0, \frac{1}{|\varepsilon|}\delta_0]$  in the  $(\hat{x}_{ss}, \hat{x}_u)$ -coordinates. Note that this region is much larger than  $[-I, I] \times (0, I]$  if  $\varepsilon$  is small. Write  $\hat{\Pi} = (\hat{\Pi}^{ss}, \hat{\Pi}^u)$  and  $\hat{\Pi}_0 = (\hat{\Pi}_0^{ss}, \hat{\Pi}_0^u)$ . For  $\hat{x}_u \in (0, \frac{1}{|\varepsilon|}\delta_0]$ ,

$$\frac{|\hat{\Pi}^u(\hat{x}_{ss}, \hat{x}_u) - \hat{\Pi}_0^u(\hat{x}_{ss}, \hat{x}_u)|}{|\hat{x}_u|} = \frac{|\hat{x}_u^\eta k_2 |\varepsilon|^{\eta-1}|}{|\hat{x}_u|} \leq \sup |k_2| \delta_0^{\eta-1}.$$

Since this is small, if  $\delta_0$  is small, it follows that every point  $(x_{ss}, x_u) \in [-\delta_0, \delta_0] \times (0, \delta_0]$  is either eventually mapped into  $[-I|\varepsilon|, I|\varepsilon|] \times (0, I|\varepsilon|]$  by

$\Pi$ , or eventually mapped outside the domain of  $\Pi$ . Hence  $\Pi$  possesses just a stable attracting fixed point if  $\varepsilon > 0$ , whereas for  $\varepsilon < 0$ , all points of  $[-\delta_0, \delta_0] \times (0, \delta_0]$  are eventually mapped outside the domain of  $\Pi$ .

### Parameters from $\mathcal{W}_1$ .

Parametrize  $\mathcal{W}_1$  by  $(\mu, k)$ , where  $k \in [-E, E]$  is defined by  $\varepsilon = k|\mu|^{\frac{1}{1-\beta}}$ . The value of  $E$  will be considered fixed, subject to conditions obtained in the above treatment of parameter values from  $\mathcal{W}_2$ . Consider the rescaling defined by

$$\begin{pmatrix} x_{ss} \\ x_u \end{pmatrix} = \begin{pmatrix} |\mu| & r\text{sign}(\mu)|\mu|^{\frac{\beta}{1-\beta}} \\ 0 & |\mu|^{\frac{1}{1-\beta}} \end{pmatrix} \begin{pmatrix} \bar{x}_{ss} \\ \bar{x}_u \end{pmatrix} + \begin{pmatrix} p \\ 0 \end{pmatrix}.$$

The Poincaré return map  $(\bar{x}_{ss}, \bar{x}_u) \mapsto \bar{\Pi}(\bar{x}_{ss}, \bar{x}_u; \mu, k)$  in rescaled coordinates and with parameters  $(\mu, k)$ , has an expression

$$\bar{\Pi}(\bar{x}_{ss}, \bar{x}_u; \mu, k) = \begin{pmatrix} -rk\text{sign}(\mu)|\mu|^{\frac{2\beta-1}{1-\beta}} + \bar{x}_u^\eta \left[ k_1|\mu|^{\frac{\eta+\beta-1}{1-\beta}} - k_2r\text{sign}(\mu)|\mu|^{\frac{2\beta-2+\eta}{1-\beta}} \right] \\ k + \text{sign}(\mu)\bar{x}_u^\beta h + \bar{x}_u^\eta k_2|\mu|^{\frac{\eta-1}{1-\beta}} \end{pmatrix},$$

where e.g.  $h$  is evaluated at  $(x_{ss}; \gamma) = (|\mu|\bar{x}_u + r|\mu|^{\frac{\beta}{1-\beta}}\bar{x}_{ss} + p; \mu, k|\mu|^{\frac{1}{1-\beta}})$ . Note that, as  $\mu \rightarrow 0$ ,  $\bar{\Pi}(\bar{x}_{ss}, \bar{x}_u; \mu, k) \rightarrow \bar{\Pi}_0(\bar{x}_{ss}, \bar{x}_u; \mu, k)$ , where

$$\bar{\Pi}_0(\bar{x}_{ss}, \bar{x}_u; \mu, k) = \begin{pmatrix} 0 \\ k + \text{sign}(\mu)\bar{x}_u^\beta \end{pmatrix}.$$

This convergence is uniform for  $(\bar{x}_{ss}, \bar{x}_u) \in [-I, I] \times (0, I]$ , where  $I$  is a positive constant. Writing  $\bar{\Pi} = \bar{\Pi}_0 + \bar{H}$ , we have for  $r, s \in \mathbb{N}$ ,

$$\left| \frac{\partial^{r+s} \bar{H}}{\partial^r \bar{x}_{ss} \partial^s \bar{x}_u}(\bar{x}_{ss}, \bar{x}_u; \mu, k) \right| \leq \text{const}(r+s)|\mu|^\zeta |\bar{x}_u|^{\eta-s},$$

for some  $\zeta > 0$ ,  $\eta > 1$  and for  $(\bar{x}_{ss}, \bar{x}_u) \in [-I, I] \times (0, I]$ ,  $k \in [-E, E]$ .

In the above situation, we can apply the following proposition from [35].

**Proposition A.3** *Let  $(\bar{x}_{ss}, \bar{x}_u, \mu, k) \mapsto \bar{\Pi}(\bar{x}_{ss}, \bar{x}_u; \mu, k)$  be a map on  $[-I, I] \times (0, I]$ , depending on parameters  $(\mu, k)$ , that decomposes as  $\bar{\Pi} = \bar{\Pi}_0 + \bar{H}$ , where*

$$\bar{\Pi}_0(\bar{x}_{ss}, \bar{x}_u; \mu, k) = (k + \text{sign}(\mu)\bar{x}_u^\beta, 0),$$

with  $\beta$  between 0 and 1 depending smoothly on  $(\mu, k)$ , and, for  $r, s \in \mathbb{N}$ ,  $\bar{H}$  satisfies

$$\left| \frac{\partial^{r+s} \bar{H}}{\partial^r \bar{x}_{ss} \partial^s \bar{x}_u}(\bar{x}_{ss}, \bar{x}_u; \mu, k) \right| \leq \text{const}(r+s) |\mu|^\zeta |\bar{x}_u|^{\eta-s},$$

for some  $\zeta > 0$ ,  $\eta > 1$ . Then  $\bar{\Pi}$  possesses a differentiable strong stable foliation.  $\square$

By Proposition A.3, there is a strong stable foliation for  $\bar{\Pi}(\bar{x}_{ss}, \bar{x}_u; \mu, k)$  on  $[-I, I] \times (0, I]$ . Therefore,  $\bar{\Pi}$  has no  $n$ -periodic orbits, or  $n$ -homoclinic orbits, with  $n > 2$ . Note that  $\bar{x}_u \in (0, I]$  corresponds to  $x_u \in (0, I|\mu|^{\frac{\beta}{1-\beta}}]$ , an interval much smaller than  $(0, \delta_0]$  if  $\mu$  is small. As in the treatment of parameters from  $\mathcal{W}_2$ , one sees that the above conclusion in fact hold for  $x_u \in (0, \delta_0]$ . This finishes the proof of Theorem A.1.

## B Exponential expansions

In this appendix we prove Lemma 2.8, providing a normal form for  $X_\gamma$  near the singularity  $q_\gamma$ , and Proposition 2.9, yielding exponential expansions of the local transition map  $\Phi_{\text{loc}} : S \rightarrow \Sigma$ .

PROOF OF LEMMA 2.8. Given the set of differential equations (2.5), where  $F^{ss}$  and  $F^s$  are quadratic and higher order terms, consider a coordinate change  $(x_{ss}, x_s, x_u) \mapsto (y_{ss}, y_s, y_u)$  of the form

$$\begin{aligned} y_{ss} &= x_{ss} + p^{ss}(x_u; \gamma)x_{ss} + p^s(x_u; \gamma)x_s, \\ y_s &= x_s + q^{ss}(x_u; \gamma)x_{ss} + q^s(x_u; \gamma)x_s, \\ y_u &= x_u, \end{aligned}$$

for functions  $p^{ss}, p^s, q^{ss}, q^s$  which vanish at  $x_u = 0$ . Write the differential equations in the new coordinates  $(y_{ss}, y_s, y_u)$  as

$$\begin{aligned} \dot{y}_{ss} &= -\alpha y_{ss} + G^{ss}(y_{ss}, y_s, y_u; \gamma)y_{ss} + G^s(y_{ss}, y_s, y_u; \gamma)y_s, \\ \dot{y}_s &= -\beta y_s + H^{ss}(y_{ss}, y_s, y_u; \gamma)y_{ss} + H^s(y_{ss}, y_s, y_u; \gamma)y_s, \\ \dot{y}_u &= y_u. \end{aligned}$$

At  $y_{ss}, y_s = 0$ , we have

$$\begin{aligned} G^{ss}(0, 0, y_u; \gamma) &= \dot{p}^{ss} + h.o.t., \\ G^s(0, 0, y_u; \gamma) &= \dot{p}^s + (\alpha - \beta)p^s + h.o.t., \\ H^{ss}(0, 0, y_u; \gamma) &= \dot{q}^{ss} + (\beta - \alpha)q^{ss} + h.o.t., \\ H^s(0, 0, y_u; \gamma) &= \dot{q}^s + h.o.t., \end{aligned}$$

where *h.o.t.* stands for higher order terms in  $(p^{ss}, p^s, q^{ss}, q^s, y_u)$ , compare [32], [9]. We seek functions  $p^{ss}, p^s, q^{ss}, q^s$  of  $y_u = x_u$  so that  $G^{ss}, \dots, H^s$  vanish at  $y_{ss}, y_s = 0$ . Considering  $p^{ss}, p^s, q^{ss}, q^s$  as variables, this demand yields differential equations for  $(p^{ss}, p^s, q^{ss}, q^s, y_u)$ ;

$$\begin{aligned} \dot{p}^{ss} &= h.o.t., \\ \dot{p}^s &= (\beta - \alpha)p^s + h.o.t., \\ \dot{q}^{ss} &= (\alpha - \beta)q^{ss} + h.o.t., \\ \dot{q}^s &= h.o.t., \\ \dot{y}_u &= y_u. \end{aligned}$$

The eigenvalues of the linearized differential equations, at  $p^{ss}, p^s, q^{ss}, q^s, y_u = 0$ , are  $\beta - \alpha, 0, 0, \alpha - \beta, 1$ . Note that  $\beta - \alpha < 0 < \alpha - \beta < 1$ . Hence we obtain the desired functions  $p^{ss}, p^s, q^{ss}, q^s$  by constructing the one dimensional strong unstable manifold for the above system of differential equations.  $\square$

The proof of Proposition 2.9 relies on a precisement of estimates derived in [32], [8], [9].

**PROOF OF PROPOSITION 2.9.** Instead of determining an orbit piece between the cross sections  $S$  and  $\Sigma$  by its initial coordinates in  $S$ , one can determine it by one stable coordinate in  $S$  together with the transition time  $\tau$  required to flow to  $\Sigma$ : for  $\tau > 0$  and  $\xi_s$  with  $|\xi_s| < 1$ , there is a unique orbit

$$x(t, \tau, \xi_s; \gamma) = (x_{ss}, x_s, x_u)(t, \tau, \xi_s; \gamma)$$

of  $X_\gamma$ , so

$$\frac{d}{dt}x(t, \tau, \xi_s; \gamma) = X_\gamma(x(t, \tau, \xi_s; \gamma)),$$



satisfying

$$\begin{aligned}x_{ss}(0, \tau, \xi_s; \gamma) &= 1, \\x_s(0, \tau, \xi_s; \gamma) &= \xi_s, \\x_u(\tau, \tau, \xi_s; \gamma) &= 1.\end{aligned}$$

This statement is deduced from the usual initial value formulation by noting that  $x_u(0, \tau, \xi_s; \gamma) = e^{-\tau}$ . However, in the above formulation the asymptotics for the local transition map become better amenable. The formulation generalizes to more dimensions and goes then under the name Shil'nikov variables, see [41], [8].

We will first show the following lemma, providing estimates on  $x_{ss}(t, \tau, \xi_s; \gamma)$  and  $x_s(t, \tau, \xi_s; \gamma)$ . The asymptotics of  $x_s$  is as in [41], [8]. For  $x_{ss}$  we can obtain a more precise expansion because of the eigenvalue conditions we assume. Indeed, from  $|x_s(t, \tau, \xi_s; \gamma)| \leq C_0 e^{-\beta t}$  and  $2\beta(\gamma) > \alpha(\gamma)$  for  $\gamma$  small, it follows that  $|x_s^2(t, \tau, \xi_s; \gamma)| \leq C_0 e^{-2\beta t}$  is much smaller than  $e^{-\alpha t}$  for  $t$  large. As we will show in the next lemma, it follows from this and Lemma 2.8 that  $x_{ss}(t, \tau, \xi_s; \gamma)$  converges at an exponential rate  $e^{-\alpha t}$  to 0 as  $t \rightarrow \infty$ .

**Lemma B.1** *For  $k \geq 0$ , there are positive constants  $C_k$  so that, for  $0 \leq t \leq \tau$  and  $\gamma$  near 0,*

$$\begin{aligned}\left| \frac{\partial^k}{\partial(t, \xi_s, \gamma)^k} x_{ss}(t, \tau, \xi_s; \gamma) \right| &\leq C_k e^{-\alpha t}, \\ \left| \frac{\partial^k}{\partial(t, \xi_s, \gamma)^k} x_s(t, \tau, \xi_s; \gamma) \right| &\leq C_k e^{-\beta t}.\end{aligned}$$

Furthermore, for the derivatives with respect to  $\tau$ ,

$$\begin{aligned}\left| \frac{\partial^k}{\partial(t, \tau, \xi_s, \gamma)^k} \frac{\partial}{\partial \tau} x_{ss}(t, \tau, \xi_s; \gamma) \right| &\leq C_k e^{-\alpha t + (t-\tau)}, \\ \left| \frac{\partial^k}{\partial(t, \tau, \xi_s, \gamma)^k} \frac{\partial}{\partial \tau} x_s(t, \tau, \xi_s; \gamma) \right| &\leq C_k e^{-\beta t + (t-\tau)}.\end{aligned}$$

PROOF. To simplify the notation we write e.g.  $x(t)$  for  $x(t, \tau, \xi_s; \gamma)$ . Recall that  $\delta$  is the distance of the sections  $S$  and  $\Sigma$  to the origin, before rescaling, see (2.6), (2.7). Because of the applied rescaling  $(x_{ss}, x_s, x_u) \mapsto (x_{ss}, x_s, x_u)/\delta$ , we have

$$|F^{ss}(x_{ss}, x_s, x_u; \gamma)|, |F^s(x_{ss}, x_s, x_u; \gamma)| \leq C\delta, \quad (\text{B.1})$$

for some  $C > 0$ , uniformly in  $(x_{ss}, x_s, x_u, \gamma)$ . By the variation of constants formula,

$$x_{ss}(t) = e^{-\alpha t} + \int_0^t e^{-\alpha(t-s)} F^{ss}(x(s)) ds, \quad (\text{B.2})$$

$$x_s(t) = e^{-\beta t} \xi_s + \int_0^t e^{-\beta(t-s)} F^s(x(s)) ds. \quad (\text{B.3})$$

For  $\kappa, \lambda > 0$  and a finite dimensional vector space  $E$  with norm  $\| \cdot \|$ , let

$$\Sigma_{\kappa, \lambda}([0, \tau], E) = \{y \in C^0([0, \tau], E); \sup_{0 \leq t \leq \tau} \|y(t)\| e^{\kappa t + \lambda(\tau-t)} < \infty\}.$$

Equipped with the norm

$$\|y\|_{\kappa, \lambda} = \sup_{0 \leq t \leq \tau} \|y(t)\| e^{\kappa t + \lambda(\tau-t)},$$

$\Sigma_{\kappa, \lambda}([0, \tau], E)$  is a Banach space.

Let  $\mathfrak{Y} = (\mathfrak{Y}^{ss}, \mathfrak{Y}^s)$  be the map on  $C^0([0, \tau], \mathbb{R}^2)$  that maps  $(x_{ss}, x_s)$  to the right hand side of (B.2), (B.3). Let  $\mathbf{B}_R$  denote the ball of radius  $R$  in  $\Sigma_{\alpha, 0}([0, \tau], \mathbb{R}) \times \Sigma_{\beta, 0}([0, \tau], \mathbb{R})$ . We claim that for  $\|\xi_s\| \leq 1$ , there exists  $R > 0$  so that

- $\mathfrak{Y}$  maps  $\mathbf{B}_R$  inside itself,
- $\mathfrak{Y}$  is a contraction on  $\mathbf{B}_R$ .

The fixed point of  $\mathfrak{Y}$ , providing the orbit  $x$ , therefore satisfies the estimates in the statement of the lemma.

The claim is obtained using (B.1), Lemma 2.8, and the observation that  $2\beta(\gamma) > \alpha(\gamma)$  for  $\gamma$  small. Since the arguments closely follow those in [8], we leave performing these estimates to the reader. One treats (higher order) derivatives by differentiating (B.2), (B.3) and using the obtained identities to define a map on an appropriate weighted Banach space. Performing estimates as above one shows that this map is a contraction on some ball in the weighted Banach space. For details we refer to [8].  $\square$

To obtain more precise asymptotics, we study the functions

$$\begin{aligned} z_{ss}(u, \tau, \xi_s; \gamma) &= e^{\alpha(\tau-u)} x_{ss}(\tau - u, \tau, \xi_s; \gamma), \\ z_s(u, \tau, \xi_s; \gamma) &= e^{\beta(\tau-u)} x_s(\tau - u, \tau, \xi_s; \gamma). \end{aligned}$$

**Lemma B.2** *The limit functions*

$$\begin{aligned} z_{ss}^\infty(u, \xi_s; \gamma) &= \lim_{\tau \rightarrow \infty} z_{ss}(u, \tau, \xi_s; \gamma), \\ z_s^\infty(u, \xi_s; \gamma) &= \lim_{\tau \rightarrow \infty} z_s(u, \tau, \xi_s; \gamma) \end{aligned}$$

exist as smooth functions of  $(u, \xi_s; \gamma)$ . For any  $0 < \sigma^{ss} < 2\beta(0) - \alpha(0)$  and  $0 < \sigma^s < \beta(0)$ , there are  $C_k$  so that, for  $0 \leq u \leq \tau$  and  $\gamma$  small,

$$\begin{aligned} \left| \frac{\partial^k}{\partial(u, \tau, \xi_s, \gamma)^k} (z_{ss}(u, \tau, \xi_s; \gamma) - z_{ss}^\infty(u, \xi_s; \gamma)) \right| &\leq C_k e^{\sigma^{ss}(u-\tau)}, \\ \left| \frac{\partial^k}{\partial(u, \tau, \xi_s, \gamma)^k} (z_s(u, \tau, \xi_s; \gamma) - z_s^\infty(u, \xi_s; \gamma)) \right| &\leq C_k e^{\sigma^s(u-\tau)}. \end{aligned}$$

PROOF. We will first show that

$$\left| \frac{\partial}{\partial \tau} z_{ss}(u, \tau, \xi_s; \gamma) \right| \leq C e^{\sigma^{ss}(u-\tau)}, \quad (\text{B.4})$$

$$\left| \frac{\partial}{\partial \tau} z_s(u, \tau, \xi_s; \gamma) \right| \leq C e^{\sigma^s(u-\tau)}, \quad (\text{B.5})$$

for some  $C$ . From this it follows that  $z_{ss}^\infty(u, \xi_s; \gamma) = \lim_{\tau \rightarrow \infty} z_{ss}(u, \tau, \xi_s; \gamma)$  and  $z_s^\infty(u, \xi_s; \gamma) = \lim_{\tau \rightarrow \infty} z_s(u, \tau, \xi_s; \gamma)$  exist and

$$\begin{aligned} |z_{ss}(u, \tau, \xi_s; \gamma) - z_{ss}^\infty(u, \xi_s; \gamma)| &\leq C e^{-\sigma^{ss}(\tau-u)}, \\ |z_s(u, \tau, \xi_s; \gamma) - z_s^\infty(u, \xi_s; \gamma)| &\leq C e^{-\sigma^s(\tau-u)}. \end{aligned}$$

As in the proof of Lemma B.1, we simplify the notation and write e.g.  $z_{ss}(t)$  for  $z_{ss}(t, \tau, \xi_s; \gamma)$ . We have

$$z_{ss}(u) = 1 + \int_0^{\tau-u} e^{\alpha s} F^{ss}(x(s)) ds, \quad (\text{B.6})$$

$$z_s(u) = \xi_s + \int_0^{\tau-u} e^{\beta s} F^s(x(s)) ds. \quad (\text{B.7})$$

Compute

$$\frac{\partial}{\partial \tau} z_{ss}(u) = e^{\alpha(\tau-u)} F^{ss}(x(\tau-u)) + \int_0^{\tau-u} e^{\alpha s} \frac{\partial}{\partial \tau} F^{ss}(x(s)) ds, \quad (\text{B.8})$$

$$\frac{\partial}{\partial \tau} z_s(u) = e^{\beta(\tau-u)} F^s(x(\tau-u)) + \int_0^{\tau-u} e^{\beta s} \frac{\partial}{\partial \tau} F^s(x(s)) ds. \quad (\text{B.9})$$

Lemma B.1 yields, for  $i = ss, s$ ,

$$\begin{aligned} |F^i(x(s))| &\leq C_0 e^{-2\beta s}, \\ \left| \frac{\partial}{\partial \tau} F^i(x(s)) \right| &\leq C_0 e^{-2\beta s + (s-\tau)}. \end{aligned}$$

Direct estimates now prove (B.4) and (B.5), compare [9]. Estimates for derivatives are obtained similarly, by differentiating (B.6) and (B.7).  $\square$

From the above lemmas we obtain expansions

$$x_{ss}(\tau, \tau, \xi_s; \gamma) = e^{-\alpha\tau} (\psi^{ss}(\xi_s; \gamma) + T^{ss}(\xi_s, \tau; \gamma)), \quad (\text{B.10})$$

$$x_s(\tau, \tau, \xi_s; \gamma) = e^{-\beta\tau} (\psi^s(\xi_s; \gamma) + T^s(\xi_s, \tau; \gamma)). \quad (\text{B.11})$$

Here  $T^{ss}$  and  $T^s$  as well as their derivatives are of order  $\mathcal{O}(e^{-\sigma^{ss}\tau})$  resp.  $\mathcal{O}(e^{-\sigma^s\tau})$  as  $\tau \rightarrow \infty$ . By (2.2) we have that  $\psi^s(0; \gamma) = 0$ . It is not hard to see that  $\frac{\partial}{\partial \xi_s} \psi^s(0; \gamma) \neq 0$ . Proposition 2.9 is now easily obtained. Indeed, from  $x_u(0, \tau, \xi_s; \gamma) = e^{-\tau} = 1$  we get  $\tau = -\ln x_u$ . Put this in the expansion formulas (B.10), (B.11) for  $x_{ss}(\tau, \tau, \xi_s; \gamma)$  and  $x_s(\tau, \tau, \xi_s; \gamma)$ .  $\square$

## References

- [1] J.C. Alexander, J.A. Yorke, On the continuability of periodic orbits of parametrized three-dimensional differential equations, *Journ. Diff. Eq.* **49** (1983), 171-184.
- [2] K.T. Alligood, J.A. Yorke, Families of periodic orbits: virtual periods and global continuability, *Journ. Diff. Eq.* **55** (1984), 59-71.
- [3] K.T. Alligood, J. Mallet-Paret, J.A. Yorke, An index for the global continuation of relatively isolated sets of periodic orbits, in *Geometric dynamics*, Lect. Notes. Math., Vol. 1007, Springer-Verlag, 1983, pp. 1-21.
- [4] G.R. Belitskii, Functional equations and conjugacy of local diffeomorphisms of a finite smoothness class, *Functional Anal. Appl.* **7** (1973), 268-277.
- [5] P. Brunovsky, On one-parameter families of diffeomorphisms, *Commun. Math. Univers. Carolinae* **11** (1970), 559-582.

- [6] S.-N. Chow, B. Deng, B. Fiedler, Homoclinic bifurcation at resonant eigenvalues, *Journ. Dynamics Diff. Eq.* **2** (1990), 177-244.
- [7] P. Coullet, C. Tresser, Itérations d'endomorphismes et groupe de renormalisation, *J. de Physique* **C5** (1978), 25.
- [8] B. Deng, The Shil'nikov problem, exponential expansion, strong  $\lambda$ -lemma,  $C^1$ -linearization, and homoclinic bifurcation, *Journ. Diff. Eq.* **79** (1989), 189-231.
- [9] B. Deng, Exponential expansion with Šil'nikov's saddle-focus, *Journ. Diff. Eq.* **82** (1989), 156-173.
- [10] M.J. Feigenbaum, Quantitative universality for a class of nonlinear transformations, *Journ. Stat. Phys.* **19** (1978), 669-706.
- [11] B. Fiedler, Global pathfollowing of homoclinic orbits in two-parameter flows, in Pitman Res. Notes Math., Vol. 352, Longman, 1996, pp. 79-146.
- [12] J.-M. Gambaudo, Ordre, desordre, et frontière des système Morse-Smale, thesis, l'Université de Nice, 1987.
- [13] P. Gaspard, R. Kapral, G. Nicolis, Bifurcation phenomena near homoclinic systems: a two parameter analysis, *Journ. Stat. Phys.* **35** (1984), 697-727.
- [14] P. Glendinning, C. Sparrow, Local and global behaviour near homoclinic orbits, *Journ. Stat. Phys.* **35** (1984), 645-696.
- [15] J. Guckenheimer, P.J. Holmes, *Nonlinear oscillations, dynamical systems and bifurcations of vector fields*, Springer Verlag (1983).
- [16] M. Hirsch, C. Pugh, M. Shub, *Invariant Manifolds*, Lect. Notes Math., Vol. 583, 1977, Springer-Verlag.
- [17] A.J. Homburg, H. Kokubu, M. Krupa, The cusp horseshoe and its bifurcations in the unfolding of an inclination-flip homoclinic orbit, *Ergod. Th. & Dynam. Sys.* **14** (1994), 667-693.
- [18] A.J. Homburg, *Global Aspects of Homoclinic Bifurcations of Vector Fields*, Memoirs A.M.S., Vol. 578, A.M.S., 1996.

- [19] A.J. Homburg, B. Krauskopf, Resonant homoclinic flip bifurcations, *Journ. Dynamics Diff. Eq.* **12** (2000), 807-850.
- [20] A.J. Homburg, T. Young, Universal scalings in homoclinic doubling cascades, to appear in *Commun. Math. Phys.*
- [21] M. Kisaka, H. Kokubu, H. Oka, Bifurcations to  $N$ -homoclinic orbits and  $N$ -periodic orbits in vector fields, *Journ. Dynamics Diff. Eq.* **5** (1993), 305-357.
- [22] M. Kisaka, H. Kokubu, H. Oka, Supplement to homoclinic doubling bifurcation in vector fields, in *Dynamical Systems* (Eds: Bamon, R., Labarca, R., Lewowicz, J. and Palis, J.), Pitman Research Notes Math., Vol. 285, Longman, 1993, pp. 92-116.
- [23] H. Kokubu, M. Komuro, H. Oka, Multiple homoclinic bifurcations from orbit-flip. I. Successive homoclinic doublings. *Int. Journ. Bif. Chaos* **6** (1996), 833-850.
- [24] H. Kokubu, V. Naudot, Existence of infinitely many homoclinic doubling bifurcations from some codimension three homoclinic orbits, *Journ. Dynamics Diff. Eq.* **9** (1997), 445-462.
- [25] J. Mallet-Paret, J.A. Yorke, Snakes: oriented families of periodic orbits, their sources, sinks, and continuation, *Journ. Diff. Eq.* **43** (1982), 419-450.
- [26] W. de Melo, S. van Strien, *One Dimensional Dynamics*, Springer-Verlag, 1993.
- [27] N. Metropolis, M.L. Stein, P.R. Stein, On finite limit sets for transformations on the unit interval, *J. Combinatorial Theory Ser. A* **15** (1973), 25-44.
- [28] V. Naudot, Bifurcations homoclines des champs de vecteurs en dimension trois, thesis, l'Université de Bourgogne, Dijon, 1996.
- [29] V. Naudot, Strange attractor in the unfolding of an inclination-flip homoclinic orbit, *Ergod. Th. & Dynam. Syst.* **16** (1996), 1071-1086.

- [30] B.E. Oldeman, B. Krauskopf, A.R. Champneys, Death of period-doublings: locating the homoclinic-doubling cascade, *Physica D* **146** (2000), 100-120.
- [31] B.E. Oldeman, B. Krauskopf, A.R. Champneys, Numerical unfoldings of resonant homoclinic flip bifurcations, to appear in *Nonlinearity*.
- [32] I.M. Ovsyannikov, L.P. Shil'nikov, On systems with saddle-focus homoclinic curve, *Math. USSR Sbornik*, **58**, 1987, 557-574.
- [33] J. Palis, F. Takens, *Hyperbolicity and sensitive chaotic dynamics at homoclinic bifurcations*, Cambridge Univ. Press, 1993.
- [34] M. Peixoto, On an approximation theorem of Kupka and Smale, *Journ. Diff. Eq.* **3** (1967), 214-227.
- [35] M.R. Rychlik, Lorenz attractors through Sil'nikov-type bifurcation. Part I, *Ergod. Th. & Dynam. Syst.* **10** (1990), 793-821.
- [36] B. Sandstede, Verzweigungstheorie homokliner Verdopplungen, thesis, University of Stuttgart, 1993.
- [37] B. Sandstede, Constructing dynamical systems having homoclinic bifurcation points of codimension two, *Journ. Dynamics Diff. Eq.* **9** (1997), 269-288.
- [38] B. Sandstede, Center manifolds for homoclinic solutions, *Journ. Dynamics Diff. Eq.* **12** (2000), 449-510.
- [39] A.L. Shil'nikov, On bifurcations of the Lorenz attractor in the Shimizu-Morioka model, *Physica D* **62** (1993), 338-346.
- [40] L.P. Shil'nikov, A case of the existence of a countable number of periodic motions, *Soviet Math. Dokl.* **6** (1965), 163-166.
- [41] L.P. Shil'nikov, On the Poincaré-Birkhoff problem, *Math. USSR Sbornik* **3** (1967), 353-371.
- [42] J. Sotomayor, Generic bifurcations of dynamical systems, in *Dynamical Systems*, edited by M. Peixoto, Academic Press, 1973, pp. 561-582.

- [43] S. Sternberg, On the structure of local homeomorphisms of Euclidean  $n$ -space, II, *Amer. Journ. Math.* **80** (1958), 623-631.
- [44] E. Yanagida, Branching of double pulse solutions from single pulse solutions in nerve axon equations, *Journ. Diff. Eq.* **66** (1987), 243-262.
- [45] J.A. Yorke, K.T. Alligood, Cascades of period doubling bifurcations: a prerequisite for horseshoes, *Bull. A.M.S.* **9** (1983), 319-322.