

Information & Communication



Bachelor Informatica 2014/15

January 2015

Some of these slides are copied from or heavily inspired by the University of Illinois at Chicago, [ECE 534: Elements of Information Theory](#) course given in Fall 2013 by Natasha Devroye

Thank you very much for the kind permission to re-use them here!

Christian Schaffner



- me
- pure mathematics at ETH Zurich
- PhD from Aarhus, Denmark
- research: quantum cryptography
- c.schaffner@uva.nl
- plays ultimate frisbee

Practicalities

- final grade consists of 50-50:
 - homework series, to be handed in and graded
 - student presentations
 - final report
- details on course homepage:
<http://homepages.cwi.nl/~schaffne/courses/infcom/2014/>

Expectations

We expect from you

- be on time
- code of honor (do not cheat)
- focus
- ask questions!

Why multitasking is bad for learning: <https://medium.com/@cshirky/why-i-just-asked-my-students-to-put-their-laptops-away-7f5f7c50f368>

Expectations

We expect from you

- be on time
- code of honor (do not cheat)
- focus
- ask questions!

You can expect from us

- be on time
- make clear what goals are
- listen to you and respond to email requests
- keep website up to date

Why multitasking is bad for learning: <https://medium.com/@cshirky/why-i-just-asked-my-students-to-put-their-laptops-away-7f5f7c50f368>

Questions ?

What is communication?

What is communication?

“The fundamental problem of communication is that of reproducing at one point either exactly or approximately a message selected at another point.” - C.E. Shannon, 1948

What is communication?

“The fundamental problem of communication is that of reproducing at one point either exactly or approximately a message selected at another point.” - C.E. Shannon, 1948



What is communication?

“The fundamental problem of communication is that of reproducing at one point either exactly or approximately a message selected at another point.” - C.E. Shannon, 1948

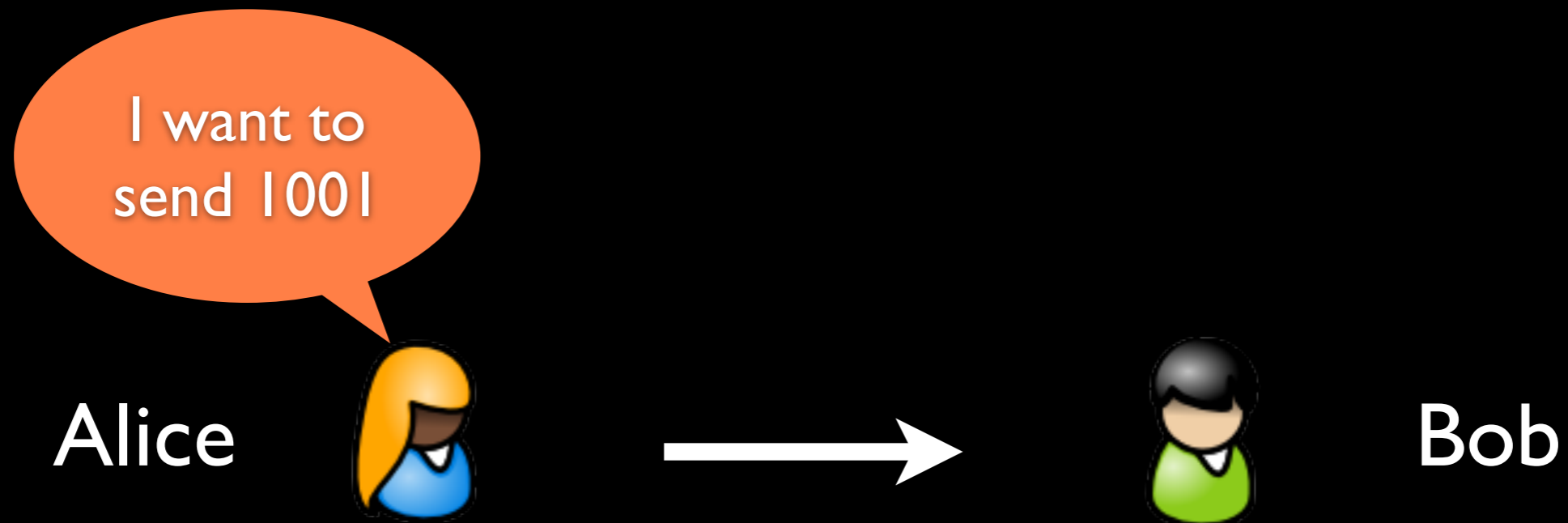

What is communication?

“The fundamental problem of communication is that of reproducing at one point either exactly or approximately a message selected at another point.” - C.E. Shannon, 1948

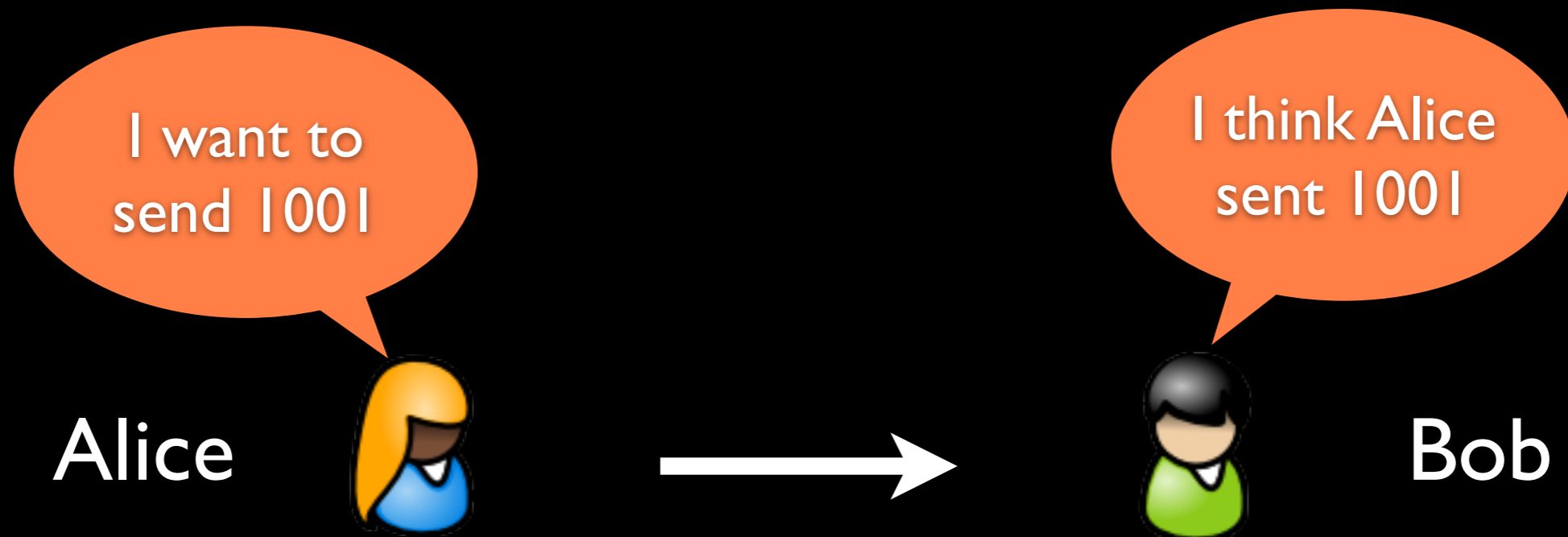

Generic communication block diagram

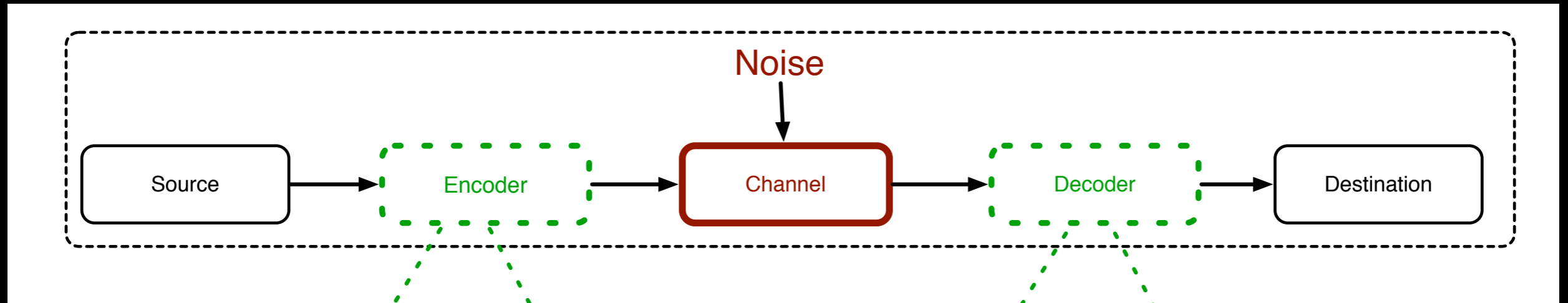

Generic communication block diagram

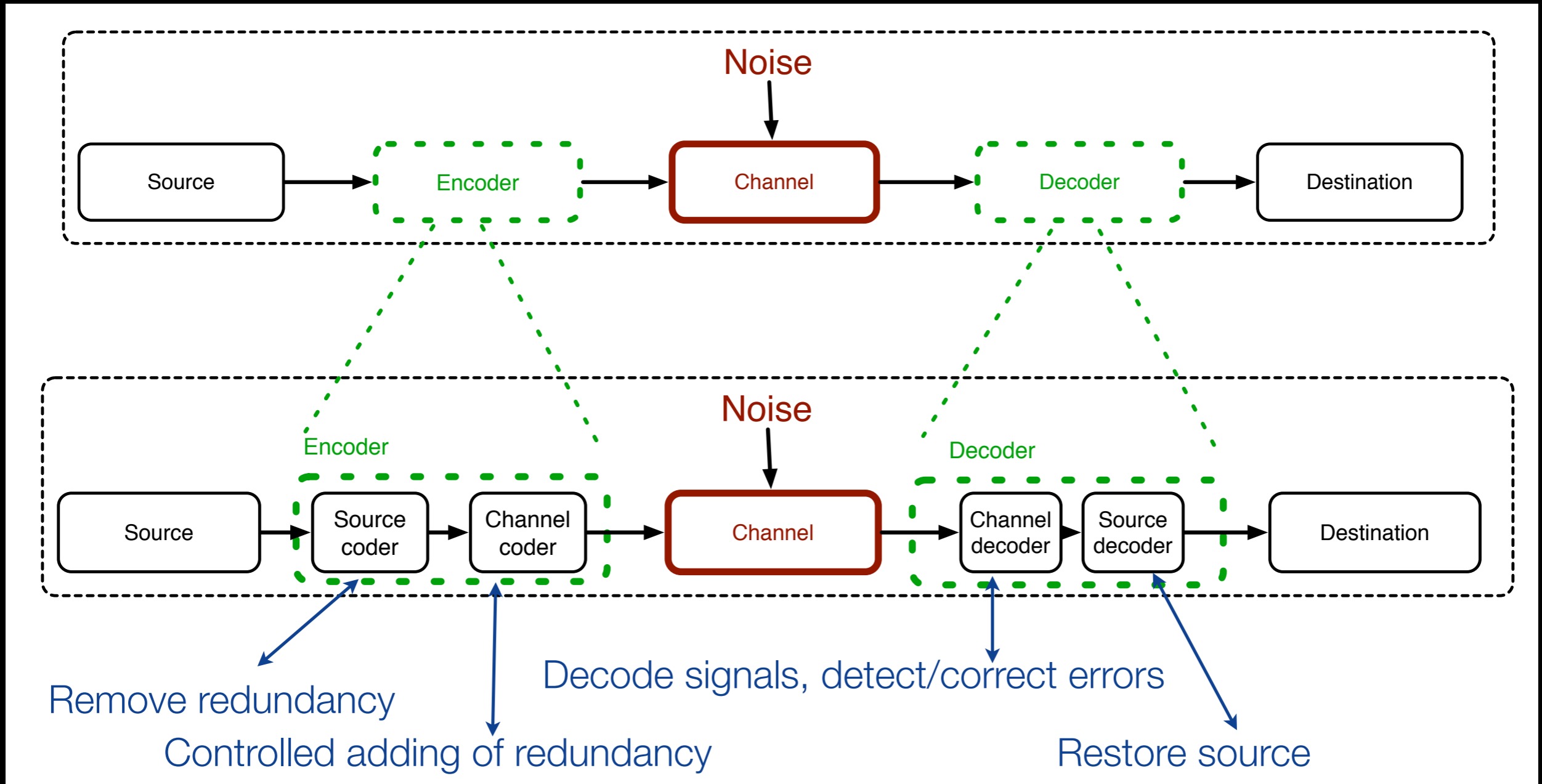

History of (wireless) communication

- Smoke signals



History of (wireless) communication

- Smoke signals
- 1861: Maxwell's equations



$$\oint \mathbf{E} \cdot d\mathbf{A} = \frac{q_{enc}}{\epsilon_0}$$
$$\oint \mathbf{B} \cdot d\mathbf{A} = 0$$
$$\oint \mathbf{E} \cdot d\mathbf{s} = -\frac{d\Phi_B}{dt}$$
$$\oint \mathbf{B} \cdot d\mathbf{s} = \mu_0 \epsilon_0 \frac{d\Phi_E}{dt} + \mu_0 i_{enc}$$

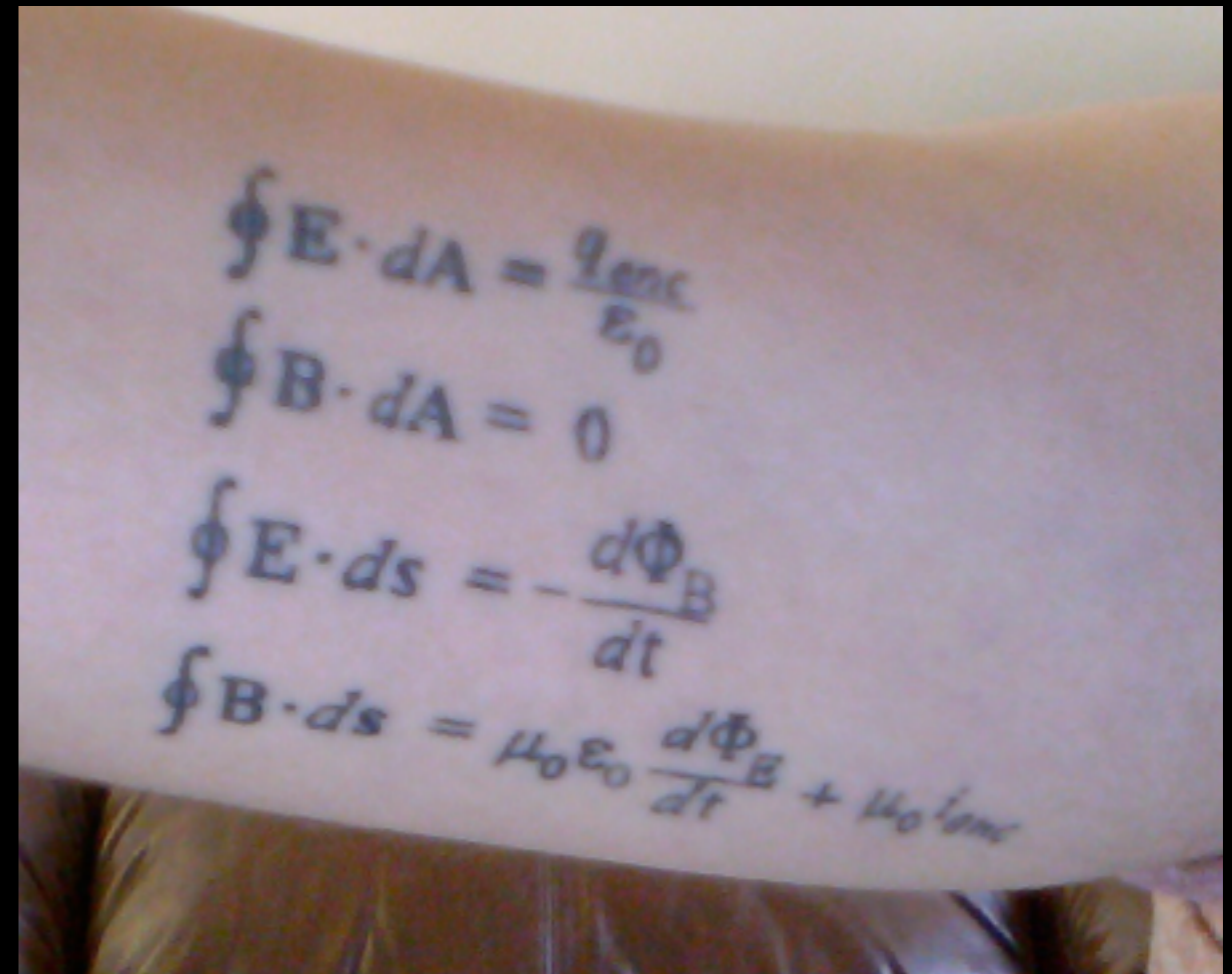

History of (wireless) communication

- Smoke signals
- 1861: Maxwell's equations
- 1900: Guglielmo Marconi demonstrates wireless telegraph

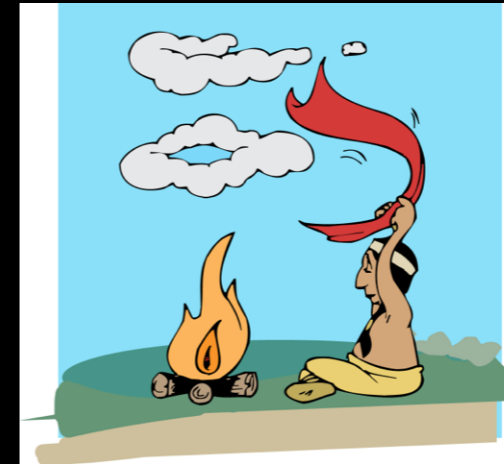

$$\oint \mathbf{E} \cdot d\mathbf{A} = \frac{q_{enc}}{\epsilon_0}$$

$$\oint \mathbf{B} \cdot d\mathbf{A} = 0$$

$$\oint \mathbf{E} \cdot d\mathbf{s} = -\frac{d\Phi_B}{dt}$$

$$\oint \mathbf{B} \cdot d\mathbf{s} = \mu_0 \epsilon_0 \frac{d\Phi_E}{dt} + \mu_0 i_{enc}$$

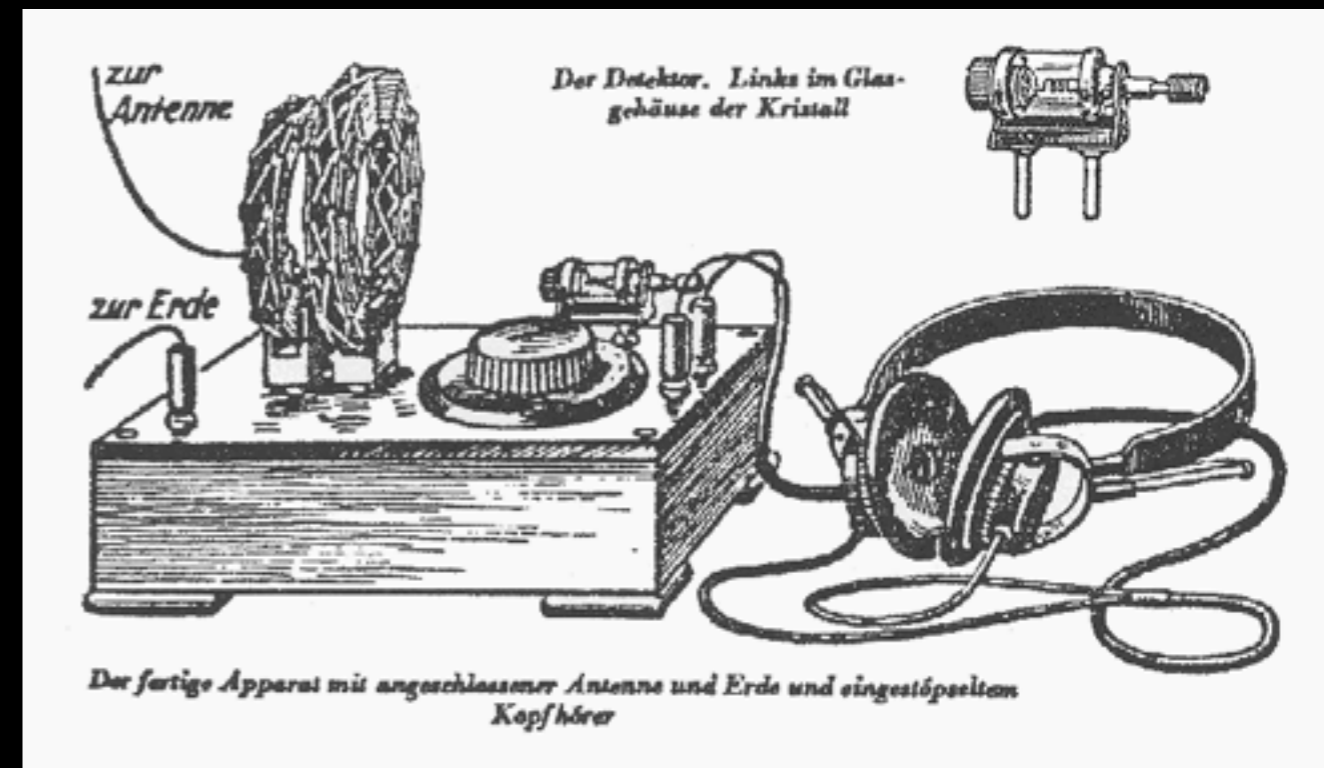

History of (wireless) communication

- Smoke signals
- 1861: Maxwell's equations
- 1900: Marconi demonstrates wireless telegraph
- 1920s: Edwin Howard Armstrong demonstrates FM radio



$$\oint \mathbf{E} \cdot d\mathbf{A} = \frac{q_{enc}}{\epsilon_0}$$

$$\oint \mathbf{B} \cdot d\mathbf{A} = 0$$

$$\oint \mathbf{E} \cdot d\mathbf{s} = -\frac{d\Phi_B}{dt}$$

$$\oint \mathbf{B} \cdot d\mathbf{s} = \mu_0 \epsilon_0 \frac{d\Phi_E}{dt} + \mu_0 i_{enc}$$



Big Open Questions

- mostly analog
- ad-hoc engineering, tailored to each application
- is there a general methodology for designing communication systems?
- can we communicate reliably in noise?
- how fast can we communicate?



Claude Elwood Shannon

1916 - 2001



- Father of Information Theory
- Graduate of MIT 1940:
“An Algebra for Theoretical Genetics”
- 1941-1972: Scientist at Bell Labs
- 1958: Professor at MIT:
When he returned to MIT in 1958, he continued to threaten corridor-walkers on his unicycle, sometimes augmenting the hazard by juggling. No one was ever sure whether these activities were part of some new breakthrough or whether he just found them amusing. He worked, for example, on a motorized pogo-stick, which he claimed would mean he could abandon the unicycle so feared by his colleagues ...
- juggling, unicycling, chess
- ultimate machine

History of (wireless) communication

- BITS !
- arguably, first to really define and use “bits”
- *"He's one of the great men of the century. Without him, none of the things we know today would exist. The whole digital revolution started with him."* -Neil Sloane, AT&T Fellow



The Bell System Technical Journal

Vol. XXVII

July, 1948

No. 3

A Mathematical Theory of Communication

By C. E. SHANNON



- Introduced a new field: Information Theory

What is
communication?

What is
information?

How much can
we compress
information?

How fast can
we
communicate?

Main Contributions of Inf Theory

Source coding

- source = random variable
- ultimate data compression limit is the source's entropy H

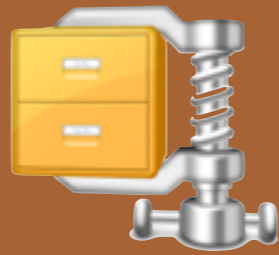

Main Contributions of Inf Theory

Source coding

- source = random variable
- ultimate data compression limit is the source's entropy H

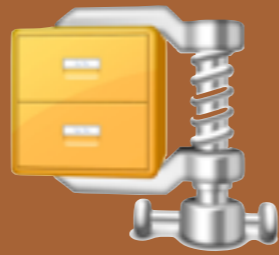

Channel coding

- channel = conditional distributions
- ultimate transmission rate is the channel capacity C

Main Contributions of Inf Theory

Source coding

- source = random variable
- ultimate data compression limit is the source's entropy H

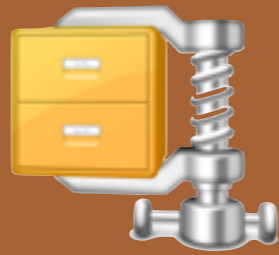

Channel coding

- channel = conditional distributions
- ultimate transmission rate is the channel capacity C

Reliable communication possible $\Leftrightarrow H < C$

Reactions to This Theory

- Engineers in disbelief
- stuck in analogue world



Error free communication in noise eh?

How to approach the predicted limits?

Shannon says: can transmit at rates up to say 4Mbps over a certain channel without error. How to do it?

It Took 50 Years To Do It

How to approach
the predicted limits?

review article by [[Costello Forney 2006](#)]

It Took 50 Years To Do It

- 50's: algebraic codes

How to approach
the predicted limits?

review article by [[Costello Forney 2006](#)]

It Took 50 Years To Do It

- 50's: algebraic codes
- 60's 70's: convolutional codes

How to approach
the predicted limits?

review article by [[Costello Forney 2006](#)]

It Took 50 Years To Do It

- 50's: algebraic codes
- 60's 70's: convolutional codes
- 80's: iterative codes (LDPC, turbo codes)

How to approach
the predicted limits?

review article by [[Costello Forney 2006](#)]

It Took 50 Years To Do It

- 50's: algebraic codes
- 60's 70's: convolutional codes
- 80's: iterative codes (LDPC, turbo codes)
- 2009: polar codes

How to approach
the predicted limits?

review article by [[Costello Forney 2006](#)]

It Took 50 Years To Do It

- 50's: algebraic codes
- 60's 70's: convolutional codes
- 80's: iterative codes (LDPC, turbo codes)
- 2009: polar codes

How to approach the predicted limits?

review article by [[Costello Forney 2006](#)]

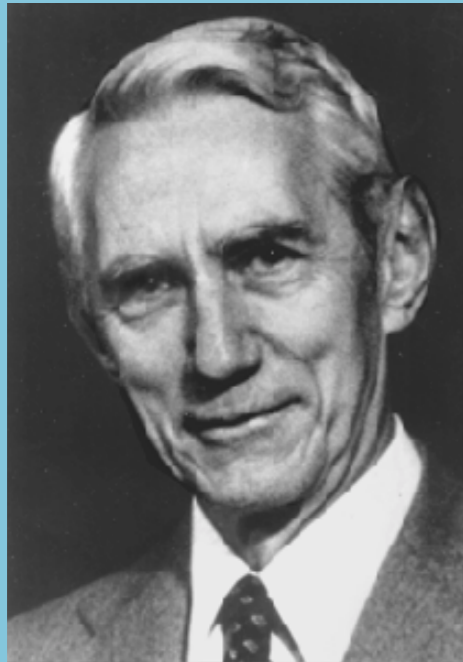

Claude Shannon — Born on the planet Earth (Sol III) in the year 1916 A.D. Generally regarded as the father of the Information Age, he formulated the notion of channel capacity in 1948 A.D. Within several decades, mathematicians and engineers had devised practical ways to communicate reliably at data rates within 1% of the Shannon limit ...

Encyclopedia Galactica, 166th ed.

Applications

- Communication Theory
- Computer Science (e.g. in cryptography)
- Physics (thermodynamics)
- Philosophy of Science (Occam's Razor)
- Economics (investments)
- Biology (genetics, bio-informatics)

Topics Overview

- Entropy and Mutual Information
- Entropy Diagrams
- Perfectly Secure Encryption
- Data Compression
- Coding Theory
- Channel-Coding Theorem
- Zero-Error Information Theory
- Noisy-Channel Theorem
- Application to Machine Learning

Questions ?

Example: Letter Frequencies

i	a_i	p_i		
1	a	0.0575	a	■
2	b	0.0128	b	■
3	c	0.0263	c	■
4	d	0.0285	d	■
5	e	0.0913	e	■
6	f	0.0173	f	■
7	g	0.0133	g	■
8	h	0.0313	h	■
9	i	0.0599	i	■
10	j	0.0006	j	■
11	k	0.0084	k	■
12	l	0.0335	l	■
13	m	0.0235	m	■
14	n	0.0596	n	■
15	o	0.0689	o	■
16	p	0.0192	p	■
17	q	0.0008	q	■
18	r	0.0508	r	■
19	s	0.0567	s	■
20	t	0.0706	t	■
21	u	0.0334	u	■
22	v	0.0069	v	■
23	w	0.0119	w	■
24	x	0.0073	x	■
25	y	0.0164	y	■
26	z	0.0007	z	■
27	–	0.1928	–	■

Figure 2.1. Probability distribution over the 27 outcomes for a randomly selected letter in an English language document (estimated from *The Frequently Asked Questions Manual for Linux*). The picture shows the probabilities by the areas of white squares.

Example: Letter Frequencies

i	a_i	p_i	
1	a	0.0575	a
2	b	0.0128	b
3	c	0.0263	c
4	d	0.0285	d
5	e	0.0913	e
6	f	0.0173	f
7	g	0.0133	g
8	h	0.0313	h
9	i	0.0599	i
10	j	0.0006	j
11	k	0.0084	k
12	l	0.0335	l
13	m	0.0235	m
14	n	0.0596	n
15	o	0.0689	o
16	p	0.0192	p
17	q	0.0008	q
18	r	0.0508	r
19	s	0.0567	s
20	t	0.0706	t
21	u	0.0334	u
22	v	0.0069	v
23	w	0.0119	w
24	x	0.0073	x
25	y	0.0164	y
26	z	0.0007	z
27	-	0.1928	-

Figure 2.1. Probability distribution over the 27 outcomes for a randomly selected letter in an English language document (estimated from *The Frequently Asked Questions Manual for Linux*). The picture shows the probabilities by the areas of white squares.

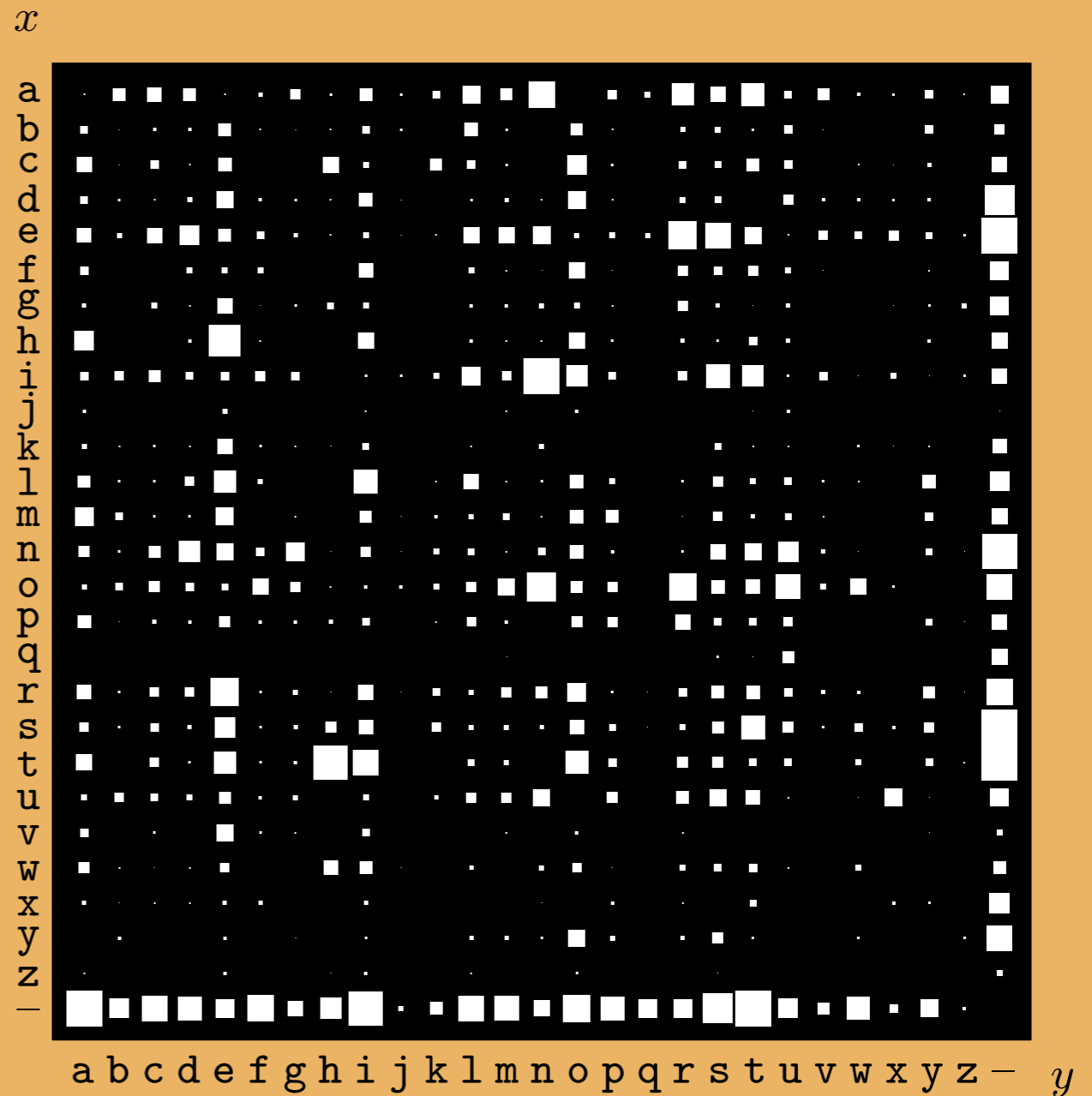

Figure 2.2. The probability distribution over the 27×27 possible bigrams xy in an English language document, *The Frequently Asked Questions Manual for Linux*.

Example: Surprisal Values

from <http://www.umsl.edu/~fraundorfp/egsurpri.html>

situation	probability $p = 1/2^{\text{\#bits}}$	surprisal $\text{\#bits} = \ln_2[1/p]$
one equals one	1	0 bits
wrong guess on a 4-choice question	3/4	$\ln_2[4/3] \sim 0.415$ bits
correct guess on true-false question	1/2	$\ln_2[2] = 1$ bit
correct guess on a 4-choice question	1/4	$\ln_2[4] = 2$ bits
seven on a pair of dice	$6/6^2 = 1/6$	$\ln_2[6] \sim 2.58$ bits
snake-eyes on a pair of dice	$1/6^2 = 1/36$	$\ln_2[36] \sim 5.17$ bits
random character from the 8-bit ASCII set	1/256	$\ln_2[2^8] = 8$ bits = 1 byte
N heads on a toss of N coins	$1/2^N$	$\ln_2[2^N] = N$ bits
harm from a smallpox vaccination	$\sim 1/1,000,000$	$\sim \ln_2[10^6] \sim 19.9$ bits
win the UK Jackpot lottery	1/13,983,816	~ 23.6 bits
RGB monitor choice of one pixel's color	$1/256^3 \sim 5.9 \times 10^{-8}$	$\ln_2[2^{8 \cdot 3}] = 24$ bits
gamma ray burst mass extinction event TODAY!	$< 1/(10^9 \cdot 365) \sim 2.7 \times 10^{-12}$	hopefully > 38 bits
availability to reset 1 gigabyte of random access memory	$1/2^{8E9} \sim 10^{-2.4E9}$	8×10^9 bits $\sim 7.6 \times 10^{-14}$ J/K
choices for 6×10^{23} Argon atoms in a 24.2L box at 295K	$\sim 1/2^{1.61E25} \sim 10^{-4.8E24}$	$\sim 1.61 \times 10^{25}$ bits ~ 155 J/K
one equals two	0	∞ bits

i	a_i	p_i	$h(p_i)$
1	a	.0575	4.1
2	b	.0128	6.3
3	c	.0263	5.2
4	d	.0285	5.1
5	e	.0913	3.5
6	f	.0173	5.9
7	g	.0133	6.2
8	h	.0313	5.0
9	i	.0599	4.1
10	j	.0006	10.7
11	k	.0084	6.9
12	l	.0335	4.9
13	m	.0235	5.4
14	n	.0596	4.1
15	o	.0689	3.9
16	p	.0192	5.7
17	q	.0008	10.3
18	r	.0508	4.3
19	s	.0567	4.1
20	t	.0706	3.8
21	u	.0334	4.9
22	v	.0069	7.2
23	w	.0119	6.4
24	x	.0073	7.1
25	y	.0164	5.9
26	z	.0007	10.4
27	-	.1928	2.4

$$\sum_i p_i \log_2 \frac{1}{p_i} \quad 4.1$$

Table 2.9. Shannon information contents of the outcomes a–z.